

**REGULAR MEETING
SUN VALLEY WATER & SEWER DISTRICT
IN THE COUNCIL CHAMBER OF THE SUN VALLEY CITY HALL**

8:30 A.M, Monday, May 20, 2019

ALL ITEMS LISTED ON THIS AGENDA ARE POTENTIAL ACTION ITEMS AND VOTES MAY BE TAKEN ON ANY ITEM LISTED

- **CALL TO ORDER**
- **APPROVAL OF MINUTES**
Regular Meeting of April 15, 2019
- **EIDE BAILLY**
- **FINANCIAL REPORT**
- **APPROVAL CHECK VOUCHERS AND PAYROLL**
 1. KSTP Operations – \$52,501.65
 2. RSCI Pay Request #11- \$114,445.97
 3. Paid Invoice Report 4/15/19-5/19/19 – \$235,390.66
 4. Payment Approval Report Unpaid over \$5000 excluding recurring - \$215,118.45
 5. Payroll 4/1/19–4/14/19 - \$12,654.59
 6. Payroll 4/15/19-4/28/19 - \$13,016.33
 7. Well Fargo Credit Card Statement - \$\$71.36

- **SEWER FLOWS FOR APRIL 2019**

ELKHORN	11,796,000		
SUN VALLEY	17,950,000		
TOTAL	29,746,000	44.13%	
KETCHUM	37,659,000	55.87%	

- **KSTP REPORT**
- **WATERLINE UPSIZE REQUEST 1 WILDROSE LANE**
- **WELL #13 BENEFICIAL USE FIELD REPORT**
- **LARRY'S LANE RESURFACE**
- **WELL #14**
- **WELL #3 UPGRADE**
- **DAN SPRINGER RETIREMENT**
- **2019 BOARD ELECTION**
- **BLAINE COUNTY BOARD OF COMMISSIONERS SPECIAL MEETING**
- **EXECUTIVE SESSION**

Pursuant to, and subject to the limitation of, Idaho Code § 74-206, the Board of Directors may hold an executive session, upon the adoption, by roll call vote, of a motion to do so which includes a description of the exact purpose for which it is being held.

- **ADJOURNMENT**

Any person needing special accommodations to participate in the above noticed meeting should contact Sun Valley Water & Sewer District prior to the meeting at (208) 622-7610.

**SUN VALLEY WATER AND SEWER DISTRICT
REGULAR MEETING OF THE BOARD OF DIRECTORS
IN THE COUNCIL CHAMBERS OF THE SUN VALLEY CITY HALL
Tuesday, April 15, 2019 - 8:30 a.m.**

PRESENT

Todd Stewart, Secretary, Acting Chairman
Joseph K. Humphrey, Director
Doug Brown, Director

ALSO PRESENT

Patrick McMahon, General Manager
Jeanene Parker, Treasurer
Melissa McKenzie, Office Manager
Evan Robertson, Attorney for the District
Mick Mummert, Superintendent of the Ketchum Wastewater Treatment Plant
Peter Hendricks, Mayor, City of Sun Valley
Bryce Ternet, Community Development Director, City of Sun Valley
Wendy Crosby, Finance Manager/Treasurer, City of Sun Valley
Kurt Eggers, Landscape Architect representing Peter O'Neill, Lane Ranch North

CALL TO ORDER

Acting Chairman Stewart called the Regular Meeting to order at 8:30 a.m.

APPROVAL OF MINUTES

Director Humphrey moved to approve the minutes of the regular meeting of March 18, 2019. Director Brown seconded the motion. All present were in favor.

WASTEWATER TREATMENT PLANT REPORT

Superintendent Mummert reported that the substantial completion inspection for the Headworks Project is scheduled for Friday, April 19, 2019. According to Superintendent Mummert, the PLC's for the Ketchum main sewer flow meter will be wired in this week and programmed. He will schedule a visit by the factory rep to bring the odor scrubber online. Once the scrubber is online, the headworks unit will have full functionality.

FINANCIAL REPORT

Treasurer Parker reported:

— the audit is still underway and should be complete by April 16, 2019;

—the staff is moving closer to fully implementing the recommendations in the internal controls report provided by Scott Hunsaker,;

—Treasurer Parker and Office Manager Melissa McKenzie are working together so there are two people handling deposits;

—a hard copy of the transcript of the refunding bond has been received; and

—the vendor list has been shortened to include only 188 total vendors.

General Manager McMahon reported that well production is down in recent months from last year due to fixed leaks.

Acting Chairman Stewart asked what services CH2MHill had provided in exchange for the \$7604.98 they had charged in connection with Well #13. General Manager McMahon explained that the work done by Jacobs Engineering, which had acquired CH2MHill, on the Well #13 project included: determination of net equivalent connection change from 2005, when Well #13 was first applied for, to the present; calculation of maximum daily demand and its relationship to the District's water right portfolio; and proving beneficial use for Well #13 to advance the transition from a License to an approved Water Right.

Director Humphrey moved to approve the list of unpaid check vouchers over and under \$2000.00 from 3/18/19-4/14/19 totaling \$203,780.18, payroll for the period 3/4/19 – 3/17/19 for \$13,086.39, and payroll for the period 3/18/19-3/31/19 for \$13,351.26. Director Brown seconded the motion. All present were in favor.

UPDATE ON VENDOR LIST

Director Humphrey moved to approve the addition of Idaho Bureau of Occupational Licenses to the vendor list. Director Brown seconded the motion. All present were in favor.

LANE RANCH NORTH ISSUES

General Manager McMahon gave historic perspective on the partnership between the Sun Valley Water and Sewer District and Peter O'Neill, developer of Lane Ranch North, to coordinate construction of the infrastructure in Mr. O'Neill's development and construction of the District's facilities in and near that area. General Manager McMahon explained Mr. O'Neill's concern with the perceived unsightliness of the District's fresh water reservoir following the death of a number of screening trees and his concern that runoff along a District pipeline was washing out a portion of the road. Kurt Eggers presented his perspective on Mr. O'Neill's proposed solution to the Board.

Director Humphrey moved to approve the replacement of the dead trees screening the Lane Ranch North reservoir at a cost not to exceed \$12,000.00. Director Brown seconded the motion. All present were in favor.

Director Brown moved to approve the installation of a french drain at the District's pipeline at Lane Ranch North not to exceed \$3000.00. Director Humphrey seconded the motion. All present were in favor.

WATER DISTRICT 37 UPDATE

The Board reviewed Water District 37 meeting minutes.

APPROVE AND RATIFY OHIO GULCH ADDENDUM TO LEASE AND MEMORANDUM OF UNDERSTANDING

Director Humphrey moved to approve the addendum, extending the term by twelve months, to the lease agreement between Blaine County, the cities of Ketchum and Hailey and the Sun Valley Water and Sewer District to permit the depositing of sludge from the cities' wastewater treatment plants in drying fields at Ohio Gulch. Director Humphrey seconded the motion. All were in favor.

Director Humphrey moved to approve the memorandum of understanding between Hennessy Company, Blaine County, the cities of Ketchum and Hailey, and the Sun Valley Water and Sewer District that envisions the addition of sludge from the water recycling facility at Quigley Farm to the drying fields. Director Brown seconded the motion. All present were in favor.

SOUTH GATEWAY PROJECT

The Board took note of an email from the Sawtooth Development Group stating that the Group is unable to move forward with the South Gateway Project to build "attainable housing" because the Blaine County Commissioners were not willing to allow individual septic systems on lots of less than one acre, even if approved by the South Central Health District.

BANYAN TECHNOLOGY INC. SERVICE AGREEMENT

The Banyan Technology service agreement, for services from 4/1/2019 to 4/20/2020, has a 2.4% price increase over the previous year. Director Humphrey moved to approve the Banyan Technology service agreement for an additional year. Director Brown seconded the motion. All present were in favor.

ADJOURNMENT

Having no further business to conduct, Acting Chairman Stewart declared the meeting adjourned at 9:34 a.m.

Acting Chairman, Todd Stewart

ATTEST:

Director, Doug Brown

SUN VALLEY WATER & SEWER DISTRICT

TO: PAT MCMAHON AND THE BOARD OF DIRECTORS
FROM: JEANENE PARKER
DATE: MAY 20, 2019
SUBJECT: TREASURER'S REPORT

1. Department Accomplishments
2. Financial Results – Summary Dashboard
3. Financial Position – Balance Sheet
4. Capital Projects – Capital Water & Sewer Project Report
5. Cash Management
6. Amended Vendor List for approval
7. EIDE Bailly Vendor approval
8. ICRMP Quote approval

Sun Valley Water & Sewer District
 Fiscal Year Ending November 30, 2019

Format Consistent with Approved Budget

% Of Fiscal year that has elapsed>>>

SUMMARY BALANCE SHEET

	3/31/2019	4/30/2019																		
	33%	42%																		
ASSETS																				
Cash - Operating	299,516	96,235																		
Cash - Restricted	29,577	9,313																		
Investments	5,393,662	5,423,851																		
Taxes Receivable	5,722,755	5,529,399																		
Accounts Receivable	1,024,886	1,142,567																		
Other Current Assets	101,803	32,983																		
	44,474	60,886																		
TOTAL CURRENT ASSETS	6,893,918	6,765,834																		
Property Plant & Equipment Net of Acc Depreciation	17,732,363	17,808,866																		
Deferred Charge, Net Amortization, KSTP Contributions Assets, net of accumulated amortization	4,917,959	4,893,958																		
TOTAL ASSETS	29,544,240	29,668,658																		
LIABILITIES																				
Current Portion of Long Term Debt	528,220	528,220																		
Other Current Liabilities	403,483	419,638																		
TOTAL CURRENT LIABILITIES	931,703	947,858																		
Bonds Payable	1,933,700	1,933,700																		
	2,865,403	2,881,559																		
TOTAL LIABILITIES	27,217,220	27,033,746																		
NET POSITION																				
Contributions from Developers	4,770,493	4,770,493																		
Net Pension Liability	357,912	357,912																		
Retained Earnings - Reserved	1,324,819	1,324,819																		
Retained Earnings - Unappropriated	20,225,613	20,133,876																		
	27,217,220	27,033,746																		
BONDS OUTSTANDING																				
2013 Refund Issue - 3.00% due Sept 2019	295,000	295,000																		
2013 Issue - Bond Premium	15,762	15,762																		
2007 GO Bond (Refin 2018), 4.200-4.50% due Aug 2024	2,074,801	2,074,801																		
2009 McHanville LID Bonds, 6.35% due 2029	76,357	76,357																		
Bonds Current Portion	(528,220)	(528,220)																		
	1,933,700	1,933,700																		

AUDITOR WORKING ON BOND BALANCES

Sun Valley Water & Sewer District - Fiscal Year Ending November 30, 2019

Format consistent with Approved Budget

% Of Fiscal year that has elapsed>>>

SUMMARY FINANCIAL DASHBOARD

REVENUES

	3/31/2019 33%	3/31/2018	4/30/2019 42%	4/30/2018	FYTD 42%	APPROVED BUDGET	PERCENT ACHIEVED
Water & Sewer Charges	7,593	7,584	5,746	5,168	758,893	1,604,860	47.29%
Irrigation/Sprinkling Charges	517	1,448	902	2,747	2,117	840,000	0.25%
Property Taxes - General	79,368	74,558	79,368	74,558	396,838	953,244	41.63%
Property Taxes - Water & Sewer Bonds	54,591	50,457	54,591	50,457	272,954	655,414	41.65%
State Sales Tax and Other Revenues	10,670	4,278	12,030	8,454	95,321	117,250	81.30%
McHanville LID	622	351	690	408	3,210	16,180	19.84%
Capital Reimbursements	8,062	9,134	1,197	0	9,259		
	161,422	147,810	154,524	141,791	1,538,592	4,186,948	36.75%

OWNER PMT FOR LID

EXPENDITURES

Salaries and Related Expenses	78,266	40,666	61,818	63,484	287,769	798,135	36.06%
Operating Expenses	41,450	55,663	42,060	39,568	190,771	981,405	19.44%
KSTP Expenses	36,260	50,899	52,502	39,635	185,025	709,000	26.10%
Capital Replacement						350,000	
Depreciation & Amortization	80,026	79,498	80,026	79,498	400,130	700,000	57.16%
Non Operating Expenditures-Debt Service	0	8,451	9,856	0	28,249	645,004	4.38%

DECREASE FROM 3 PAY PERIODS IN MARCH

POWER BILL FOR MARCH & APRIL INV TOGETHER

2019 MCHANVILLE LID PMT

Total Monthly Expenditures	236,002	235,177	246,261	222,183	1,091,945	4,183,544	26.10%
-----------------------------------	---------	---------	---------	---------	-----------	-----------	--------

Monthly Excess of Revenues over Expenditures

	-74,580	-87,366	-91,737	-80,392	446,647	3,404	
--	---------	---------	---------	---------	---------	-------	--

Running Excess/Deficit of Revenues over Expenditures

	538,383		446,647		446,647		
--	---------	--	---------	--	---------	--	--

Capital Improvements

	-146,190		-132,528		-769,820	-875,220	105,400
--	----------	--	----------	--	----------	----------	---------

Use of (Addition to) Unappropriated Funds

	220,771		224,265		323,173		
--	---------	--	---------	--	---------	--	--

Net

						(871,816.00)	
--	--	--	--	--	--	--------------	--

Unspent

SUN VALLEY WATER & SEWER DISTRICT COMPARISON JANUARY 2019

	DECEMBER		JANUARY		FEBRUARY		MARCH		APRIL		MAY	
	2018	2017	2019	2018	2019	2018	2019	2018	2019	2018	2019	
WELL PRODUCTION	54,555	61,332	41,336	46,770	36,466	58,647	41,416	44,569	40,012	41,967	94,310	75,554
ELKHORN GOLF Domestic	0	0	0	0	0	0	0	0	0	0	0	426
ELKHORN GOLF Reuse	0	0	0	0	0	0	0	0	429	0	1,073	7,169
DOLLAR Snowmaking	13,843	22,356	1,220	5,817	0	3,066	81	62	0	40	0	0
KSTP Plant Total	36,679	34,272	35,648	33,191	32,337	32,404	37,011	38,991	67,405	40,464	48,799	85,706
Ketchum Total	19,582	18,198	18,750	18,096	17,674	18,096	19,871	18,096	37,659	15,214	26,409	51,698
SWWSD Total	17,097	16,074	16,898	15,095	14,653	15,030	17,140	21,522	29,746	25,250	22,390	35,808
SWWSD %	46.61%	46.90%	47.40%	45.48%	45.34%	46.38%	46.31%	55.20%	44.13%	62.40%	45.88%	39.45%
KSTP Operating Expense	26,417	47,856	36,849	33,211	32,998	39,617	36,260	50,899	52,502	39,635	45,406	47,341
System Utility	11,705	11,012	12,131	11,331	11,831	11,533	12,426	13,158	11,189	11,534	14,805	11,537
Property Tax	65,683	59,906	510,088	527,738	35,453	39,613	6,120	4,291	9,334	5,770	6,526	8,556
2004 Bond (Refin 2013)	21,827	20,144	169,522	177,456	6,666	13,320	2,034	1,443	3,102	1,940	2,194	2,922
2007 Bond (Refin 2018)	23,334	21,534	181,220	189,704	7,148	14,239	2,174	1,542	3,316	2,074	2,346	3,188

	JUNE		JULY		AUGUST		SEPTEMBER		OCTOBER		NOVEMBER	
	2018	2017	2018	2017	2018	2017	2018	2017	2018	2017	2018	2017
WELL PRODUCTION	138,279	151,734	188,539	181,293	194,420	170,269	141,742	116,446	40,915	52,370	45,163	51,698
ELKHORN GOLF Domestic	1,428	3,150	1,428	2,148	4,802	0	0	0	0	0	0	0
ELKHORN GOLF Reuse	10,648	13,595	21,538	19,022	12,105	14,199	13,710	8,154	1,330	509	0	0
DOLLAR Snowmaking	0	0	0	0	0	0	0	330	440	693	11,004	14,665
KSTP Plant Total	48,260	68,327	43,212	45,918	39,762	39,695	31,686	31,352	32,887	29,783	27,660	26,968
Ketchum Total	26,701	47,235	21,882	25,039	20,530	20,147	16,467	15,557	14,873	15,261	13,764	14,749
SWWSD Total	21,599	21,092	21,330	20,879	19,232	19,548	15,219	15,795	18,014	14,522	13,896	12,219
SWWSD %	44.67%	30.87%	49.36%	45.47%	48.37%	51.65%	48.37%	50.38%	54.78%	48.76%	50.24%	45.31%
KSTP Operating Expense	38,831	32,373	37,753	51,747	42,277	38,150	39,164	36,738	39,513	34,087	51,394	29,362
System Utility	22,229	23,825	30,377	36,140	31,756	33,452	31,048	30,232	20,832	18,892	10,848	11,041
Property Tax	36,621	36,979	225,240	267,303	5,307	7,579	18,491	4,681	1,357	1,171	17,074	311
2004 Bond (Refin 2013)	12,314	12,627	75,750	91,286	1,785	1,512	1,295	1,667	456	322	93	106
2007 Bond (Refin 2018)	13,164	13,778	80,978	99,606	1,908	1,648	1,384	1,795	488	351	43	116

SUN VALLEY WATER & SEWER DIST
BALANCE SHEET
APRIL 30, 2019

ASSETS

CURRENT ASSETS

CASH

1-01-00	CASH - OPERATING CHECKING	96,235.38
1-02-00	CASH - '07 BOND FUND (2018)	4,079.35
1-04-00	CASH - '04 BOND FUND	3,854.65
1-05-00	CASH -'04 KSTP CONSTRUCT. FUND	833.18
1-05-01	CASH -'08 MCHANVILLE LID	545.60

TOTAL CASH		105,548.18
------------	--	------------

TAXES RECEIVABLE

1-06-00	TAXES RECEIVABLE - CURRENT	277,989.08
1-07-00	TAXES RECEIVABLE - DELINQUENT	2,166.65
1-08-00	TAXES RECEIVABLE - ESTIMATE	396,837.55
1-09-00	TAXES RECEIVABLE-CURRENT-BOND	191,108.27
1-10-00	TAXES REC DELIQUENT-BOND	1,510.79
1-11-00	TAXES RECEIVABLE-ESTIMATE/BOND	272,954.25

TOTAL TAXES RECEIVABLE		1,142,566.57
------------------------	--	--------------

ACCOUNTS RECEIVABLE

1-15-00	ACCOUNTS RECEIVABLE - OTHER	639.98
1-16-00	ACCOUNTS RECEIVABLE METERED LO	4,326.41
1-17-00	ACCOUNTS RECEIVABLE W/S TRADE	28,016.18

TOTAL ACCOUNTS RECEIVABLE		32,982.57
---------------------------	--	-----------

1-41-00	INVENTORY OF SUPPLIES	45,119.91
1-48-00	INVESTMENTS-'07 BOND REPAY FND	201,648.48
1-50-00	INVESTMENTS - GENERAL FUND	3,772,142.51
1-51-00	INVESTMENTS - CAP RESERVE FUND	99,114.08
1-52-00	SEWER REPLACEMENT/REPAIR FUND	412,354.83
1-53-00	INVESTMENTS-'04 BOND REPAY FND	619,396.49
1-54-00	INVESTMENTS-'04 KSTP CONST FND	1,666.71
1-54-01	INVESTMENTS-'08 MCHANVILLE LID	317,527.87
1-55-00	PREPAID EXPENSES	15,766.21

TOTAL		5,484,737.09
-------	--	--------------

TOTAL CURRENT ASSETS		6,765,834.39
----------------------	--	--------------

SUN VALLEY WATER & SEWER DIST
BALANCE SHEET
APRIL 30, 2019

FIXED ASSETS		
PROPERTY PLANT & EQUIPMENT		
1-61-00	FIXED ASSETS - LAND	668,769.88
1-62-00	FIXED ASSETS - BUILDINGS	501,922.59
1-63-00	FIXED ASSETS-IMPR NOT BLDG WTR	17,063,535.23
1-64-00	FIXED ASSETS-IMPR NOT BLDG SEW	4,047,330.44
1-65-00	FIXED ASSETS - MACH/EQ - WATER	395,406.52
1-66-00	FIXED ASSETS - MACH/EQ - SEWER	280,427.32
1-67-00	FIXED ASSETS - OFFICE EQUIPMNT	113,847.47
1-68-00	FIXED ASSETS - W.I.P. - WATER	288,640.86
1-69-00	FIXED ASSETS - W.I.P. - SEWER	1,354,319.89
1-69-50	FIXED ASSETS - REUSE	4,613,070.63
		29,327,270.83
TOTAL PROPERTY PLANT & EQUIPMENT		
ACCUM DEPRECIATION		
1-72-00	DEPRECIATION - BUILDINGS	(495,273.39)
1-73-00	DEPR - IMPR NOT BLDG - WATER	(7,571,299.68)
1-74-00	DEPR - IMPR NOT BLDG - SEWER	(2,198,446.27)
1-75-00	DEPR - MACH/EQUIP - WATER	(360,025.53)
1-76-00	DEPR - MACH/EQUIP - SEWER	(277,177.68)
1-77-00	DEPR - OFFICE EQUIPMENT	(112,648.19)
1-78-00	DEPR - REUSE	(505,533.79)
		(11,518,404.53)
TOTAL ACCUM DEPRECIATION		
DEFERRED CHARGES		
1-96-00	CONTRIBUTION - KSTP (ASSET)	11,882,881.63
1-97-00	ACCUMULATED AMORTIZATION KSTP	(7,157,134.84)
1-99-00	DOF OF RES.-PENSION OBLIGATION	168,211.00
		4,893,957.79
TOTAL DEFERRED CHARGES		
TOTAL FIXED ASSETS		22,702,824.09
TOTAL ASSETS		29,468,658.48

SUN VALLEY WATER & SEWER DIST
BALANCE SHEET
APRIL 30, 2019

LIABILITIES AND EQUITY

LIABILITIES

CURRENT LIABILITIES

2-01-00	ACCOUNTS PAYABLE	239,320.47
2-11-00	CURRENT PORTION LONG TERM DEBT	528,219.94
2-12-00	ACCR INT PAYABLE ON BONDS	43,940.21
2-16-00	SALARIES PAYABLE	17,805.12
2-17-00	SIT - PAYROLL TAXES PAYABLE	658.00
2-18-00	FIT - PAYROLL TAXES PAYABLE	1,813.64
2-19-00	FICA - PAYROLL TAXES PAYABLE	2,826.36
2-21-00	INS - PAYROLL DEDUCT PAYABLE	6,147.32
2-23-00	PERS - PAYROLL TAXES PAYABLE	3,345.48
2-24-00	DEF COMP - PAYROLL TAXES PAY	103,804.32
2-25-00	PERSI - 401K DEFINED CONTRIB.	179.53

TOTAL CURRENT LIABILITIES 947,858.37

LONG TERM LIABILITIES

2-33-00	BONDS PAYABLE-SERIES 2013	295,000.00
2-33-01	BOND PREMIUM-SERIES 2013	15,762.49
2-37-00	2007 BONDS PRINCIPAL	2,074,801.09
2-38-00	2009 MCHANVILLE LID PRINCIPAL	76,356.79
2-39-00	BONDS CURRENT PORTION	(528,219.94)

TOTAL LONG TERM LIABILITIES 1,933,700.43

TOTAL LIABILITIES 2,881,558.80

FUND EQUITY

2-63-00	CONTRIBUTIONS FROM DEVELOPERS	4,770,492.56
2-65-00	NET PENSION LIABILITY	319,368.00
2-68-00	DIF OF RES-EMPLOYER PENS ASSUM	38,544.00
2-73-00	RETAINED EARNINGS - RESERVED	1,324,818.74

UNAPPROPRIATED FUND BALANCE:

2-72-00	RETAINED EARNINGS - UNRESERVED	19,687,229.74
	REVENUE OVER EXPENDITURES - YTD	446,648.64

BALANCE - CURRENT DATE 20,133,876.38

TOTAL FUND EQUITY 26,567,099.68

TOTAL LIABILITIES AND EQUITY 29,468,658.48

SUN VALLEY WATER & SEWER DIST
REVENUES WITH COMPARISON TO BUDGET
FOR THE 5 MONTHS ENDING APRIL 30, 2019

	PERIOD ACTUAL	YTD ACTUAL	BUDGET	UNEARNED	PCNT
WATER AND SEWER REVENUE					
OPERATING REVENUES					
3-38-00 WATER MO. CHGS - SV SIDE	2,643.71	276,023.53	349,920.00	73,896.47	78.9
3-39-00 WATER MO. CHGS - ELKHORN SIDE	866.28	94,205.31	460,000.00	365,794.69	20.5
3-40-00 SEWER MO. CHGS - SV SIDE	1,420.81	281,768.13	344,440.00	62,671.87	81.8
3-41-00 SEWER MO CHGS - ELKHORN SIDE	814.76	106,895.90	449,000.00	342,104.10	23.8
3-42-00 SUMMER SPRINKLING - SV SIDE	291.06	1,259.72	290,000.00	288,740.28	.4
3-43-00 SUMMER SPRINKLING - ELKHORN	610.64	857.05	550,000.00	549,142.95	.2
3-45-00 WATER CONNECTION FEE	.00	75.00	750.00	675.00	10.0
3-46-00 SEWER CONNECTION FEE	.00	75.00	750.00	675.00	10.0
TOTAL OPERATING REVENUES	6,647.26	761,159.64	2,444,860.00	1,683,700.36	31.1
NON-OPERATING REVENUES					
3-01-00 GENERAL PROPERTY TAXES	79,367.51	396,837.55	953,244.00	556,406.45	41.6
3-02-00 BOND PROPERTY TAXES	54,590.85	272,954.25	655,414.00	382,459.75	41.7
3-19-00 PENALTY/INTEREST ON DEL TAXES	243.91	1,099.32	3,000.00	1,900.68	36.6
3-34-00 STATE SALES TAX	.00	15,332.83	33,050.00	17,717.17	46.4
3-47-00 CAPITAL IMPRV H/U FEES-SEWER	.00	3,000.00	30,000.00	27,000.00	10.0
3-69-00 OTHER REVENUES	687.00	26,496.81	10,000.00	(16,496.81)	265.0
3-71-00 INTEREST REV - GENERAL FUND	9,135.64	41,851.25	35,000.00	(6,851.25)	119.6
3-72-00 INTEREST REV - CAPITAL RESERV	215.43	1,001.70	1,000.00	(1.70)	100.2
3-73-00 INT REV - SEWER REPL/REPAIR	.00	.00	5,000.00	5,000.00	.0
3-74-00 INTEREST REV - '04 BOND FUND	1,327.03	4,282.58	50.00	(4,232.58)	8565.2
3-75-00 INTEREST REV- '04 KSTP CONSTR.	3.64	810.79	.00	(810.79)	.0
3-76-00 INTEREST REV- '07 BOND FUND	417.58	1,295.73	50.00	(1,245.73)	2591.5
3-78-00 INTEREST REV- '08 LID MCHAN.	690.46	3,210.31	100.00	(3,110.31)	3210.3
3-90-00 REIMBURSED PROJECT COSTS	1,187.49	9,259.33	16,180.00	6,920.67	57.2
TOTAL NON-OPERATING REVENUES	147,876.54	777,432.45	1,742,088.00	964,655.55	44.8
TOTAL REVENUE	154,523.80	1,538,592.09	4,186,948.00	2,648,355.91	36.8

SUN VALLEY WATER & SEWER DIST
EXPENDITURES WITH COMPARISON TO BUDGET
FOR THE 5 MONTHS ENDING APRIL 30, 2019

	PERIOD ACTUAL	YTD ACTUAL	BUDGET	UNEXPENDED	PCNT
WATER AND SEWER EXPENSE					
SALARIES & RELATED EXPENSES					
4-01-11 SALARIES - BOARD	.00	3,800.00	8,000.00	4,200.00	47.5
4-01-12 SALARIES - ADMINISTRATION	12,545.26	69,585.39	249,000.00	178,414.61	28.1
4-01-13 SALARIES - OPERATING	24,178.79	123,613.16	291,000.00	167,386.84	42.5
4-01-21 FICA EXPENSE	2,809.39	15,072.13	40,365.00	25,292.87	37.3
4-01-22 HEALTH INSURANCE EXPENSE	10,683.02	46,124.18	138,060.00	91,935.82	33.4
4-01-23 RETIREMENT EXPENSE	4,157.16	22,130.41	63,350.00	41,219.59	34.9
4-01-24 WORKERS' COMPENSATION EXPENSE	7,444.00	7,444.00	9,360.00	1,916.00	79.5
TOTAL SALARIES & RELATED EXP	61,817.62	287,769.27	798,135.00	510,365.73	36.1
SUPPLIES					
4-02-31 OFFICE SUPPLIES	706.93	5,433.26	9,000.00	3,566.74	60.4
4-02-32 OPERATING SUPPLIES	722.28	1,163.82	10,000.00	8,836.18	11.6
4-02-34 MINOR EQUIPMENT	40.87	116.43	2,500.00	2,383.57	4.7
4-02-35 FUEL AND OIL	940.91	3,489.95	14,625.00	11,135.05	23.9
4-02-38 JANITORIAL SUPPLIES	13.07	185.94	1,000.00	814.06	18.6
TOTAL SUPPLIES	2,424.06	10,389.40	37,125.00	26,735.60	28.0
OTHER EXPENSES					
4-03-40 KSTP OPERATIONS	52,501.65	185,025.42	709,000.00	523,974.58	26.1
4-03-41 CONSULTING - PROF FEES	1,304.75	18,897.94	40,000.00	21,102.06	47.2
4-03-42 AUDITING - PROF FEES	1,935.00	6,715.00	8,000.00	1,285.00	83.9
4-03-43 ATTORNEY'S FEES	8,085.00	28,980.00	90,000.00	61,020.00	32.2
4-03-44 ADVERTISING & LEGAL PUBLISH	.00	.00	1,000.00	1,000.00	.0
4-03-45 BOND FEES	.00	.00	1,500.00	1,500.00	.0
4-03-46 INSURANCE	3,153.25	15,766.25	39,780.00	24,013.75	39.6
4-03-47 TRAVEL, MEETING, ENTERTAINMENT	72.36	793.17	5,000.00	4,206.83	15.9
4-03-48 DUES, SUBSCRIPTIONS	217.71	12,523.25	20,000.00	7,476.75	62.6
4-03-49 PERSONNEL TRAINING	92.00	498.50	6,500.00	6,001.50	7.7
4-03-50 STUDIES	.00	.00	50,000.00	50,000.00	.0
4-03-51 TELEPHONE	956.87	5,458.35	9,500.00	4,041.65	57.5
4-03-52 SYSTEM UTILITIES, ELEC/GAS	11,188.88	58,715.90	275,000.00	216,284.10	21.4
4-03-54 RENT - EQUIPMENT OFFICE	232.56	1,514.32	4,000.00	2,485.68	37.9
4-03-57 UTILITIES - MTC BLDG	474.74	2,746.96	5,000.00	2,253.04	54.9
4-03-58 R/M OFFICE EQ	95.00	245.00	1,000.00	755.00	24.5
4-03-59 R/M GROUNDS	2,600.00	2,668.04	22,000.00	19,331.96	12.1
4-03-60 R/M - BUILDINGS	110.68	1,533.65	46,000.00	44,466.35	3.3
4-03-61 R/M - AUTO	17.25	790.84	10,000.00	9,209.16	7.9
4-03-62 R/M - WA EQUIPMENT	.00	.00	3,000.00	3,000.00	.0
4-03-63 R/M - WATER SYSTEM	7,699.26	14,398.00	200,000.00	185,602.00	7.2
4-03-64 R/M - SEWER SYSTEM	.00	3,434.98	70,000.00	66,565.02	4.9
4-03-65 R/M - WATER METERS	124.43	124.43	17,000.00	16,875.57	.7
4-03-67 WATER TEST FEES	90.00	551.70	5,000.00	4,448.30	11.0
4-03-69 OTHER EXPENSES	272.96	3,112.82	5,000.00	1,887.18	62.3
4-03-70 R/M - REUSE SYSTEM	912.96	912.96	10,000.00	9,087.04	9.1
TOTAL OTHER EXPENSES	92,137.31	365,407.48	1,653,280.00	1,287,872.52	22.1

**SUN VALLEY WATER & SEWER DIST
EXPENDITURES WITH COMPARISON TO BUDGET
FOR THE 5 MONTHS ENDING APRIL 30, 2019**

	<u>PERIOD ACTUAL</u>	<u>YTD ACTUAL</u>	<u>BUDGET</u>	<u>UNEXPENDED</u>	<u>PCNT</u>
CAPITAL					
4-04-70 DEPRECIATION EXPENSE	56,025.27	280,126.35	700,000.00	419,873.65	40.0
4-04-73 AMORTIZ OF CONTRIBUTION - KSTP	24,000.73	120,003.65	350,000.00	229,996.35	34.3
TOTAL CAPITAL	80,026.00	400,130.00	1,050,000.00	649,870.00	38.1
DEBT SERVICE					
4-05-81 INTEREST EXPENSE FOR BONDS	.00	18,393.75	108,824.00	90,430.25	16.9
4-05-84 INTEREST EXPENSE- LID	9,855.55	9,855.55	8,220.00	(1,635.55)	119.9
TOTAL DEBT SERVICE	9,855.55	28,249.30	117,044.00	88,794.70	24.1
TOTAL DEPARTMENT EXPENSE	246,260.54	1,091,945.45	3,655,584.00	2,563,638.55	29.9
NET REVENUE OVER EXPENDITURES	(91,736.74)	446,646.64	531,364.00	84,717.36	84.1

Report Criteria:

Detail report type printed

Vendor Number	Name	Invoice Number	Description	Seq	Invoice Date	Invoice Amount	Discount Amount	Check Amount	Check Number	Check Issue Date
35	Anderson, Anthony	013119BELL	HEALTH INSURE EXP-JU	1	01/31/2019	18.22	.00	18.22	15554	04/15/2019
		022519BELL	HEALTH INSURE EXP-JU	1	02/25/2019	29.60	.00	29.60	15554	04/15/2019
		BELL-03041	HEALTH INSURE EXP-JU	1	03/04/2019	47.82	.00	47.82	15554	04/15/2019
Total 35:						95.64	.00	95.64		
90	Benson, Chris	CHRIS-2041	HEALTH INS EXP FEB/CH	1	02/04/2019	115.39	.00	115.39	15556	04/15/2019
		ZACH-02041	HEALTH INS EXP FEB-ZA	1	02/04/2019	48.03	.00	48.03	15556	04/15/2019
Total 90:						163.42	.00	163.42		
126	BOISE OFFICE EQUIPME	IN1964354	QUARTERLY MAINT BAS	1	04/09/2019	265.49	.00	265.49	15557	04/15/2019
Total 126:						265.49	.00	265.49		
127	BOLEN'S CONTROL HOU	S1291870.00	H2O R/M-SAGEWILLOW -	1	03/08/2019	83.08	.00	83.08	15558	04/15/2019
Total 127:						83.08	.00	83.08		
170	Business As Usual	145950	OFFICE SUPPLIES/MAR -	1	03/06/2019	256.00	.00	256.00	15559	04/15/2019
Total 170:						256.00	.00	256.00		
175	CASELLE INC.	94288	CONTRACT SUPPORT-5/	1	04/01/2019	611.00	.00	611.00	4151901	04/15/2019
Total 175:						611.00	.00	611.00		
180	CH2M Hill INC.	154047CH00	BENEFICIAL USE/WATER	1	03/22/2019	2,745.21	.00	2,745.21	15550	04/15/2019
Total 180:						2,745.21	.00	2,745.21		
185	Chateau Drug	030619	JANITORIAL SUP/TOILET	1	03/06/2019	59.88	.00	59.88	15561	04/15/2019
		2042957	OFFICE SUPPLIES - SYM	1	03/21/2019	2.00	.00	2.00	15561	04/15/2019
Total 185:						61.88	.00	61.88		
190	Clear Creek Disposal	0001215419	ON CALL SVC 3/15/19	1	03/25/2019	41.81	.00	41.81	15562	04/15/2019
Total 190:						41.81	.00	41.81		
205	Color Haus	217152	BUILDING R/M-PAINT SA	1	03/06/2019	42.95	.00	42.95	15563	04/15/2019
		217186	BUILDING R/M-PAINT SA	1	03/07/2019	7.99	.00	7.99	15563	04/15/2019
		217318	BUILDING R/M-PAINT SA	1	03/13/2019	15.98	.00	15.98	15563	04/15/2019
		217532	BUILDING R/M-SIDING R	1	03/22/2019	78.75	.00	78.75	15563	04/15/2019
Total 205:						145.87	.00	145.87		
220	COX BUSINESS SERVICE	041319	INTERNET SERVICE-APR	1	04/13/2019	89.00	.00	89.00	15584	04/22/2019
Total 220:						89.00	.00	89.00		
270	Dig Line Inc	0060348-IN	DUES & SUBSCRIPTIONS	1	03/31/2019	71.70	.00	71.70	15585	04/15/2019

Vendor Number	Name	Invoice Number	Description	Seq	Invoice Date	Invoice Amount	Discount Amount	Check Amount	Check Number	Check Issue Date
Total 270:						71.70	.00	71.70		
297	FERGUSON ENTERPRIS	0704378	WATER R/M- FIRE HYDR	1	03/11/2019	2,427.59	.00	2,427.59	15551	04/15/2019
Total 297:						2,427.59	.00	2,427.59		
365	Houston Lumber Co.	014-144975	SINGLE CUT KEY (4)	1	03/14/2019	10.36	.00	10.36	15566	04/15/2019
		014-146456	BLDG R/M - CEDAR CH-D	1	03/21/2019	93.07	.00	93.07	15566	04/15/2019
		014-147264	BLDG R/M - SOFFIT SCR	1	03/25/2019	45.08	.00	45.08	15566	04/15/2019
		14-0144624	BROOM	1	03/13/2019	11.29	.00	11.29	15566	04/15/2019
Total 365:						159.80	.00	159.80		
405	ICRMP	10016-1819-	1/2 OF PREPAID EXP-10/1	1	04/05/2019	18,919.50	.00	18,919.50	15585	04/22/2019
Total 405:						18,919.50	.00	18,919.50		
430	Idaho Power	042519	SYSTEM UTILITIES-WHIT	1	04/25/2019	668.16	.00	668.16	15589	05/03/2019
		042519	SYSTEM UTILITIES-BACK	2	04/25/2019	11.27	.00	11.27	15589	05/03/2019
		042519	SYSTEM UTILITIES-LOT 1	3	04/25/2019	5.62	.00	5.62	15589	05/03/2019
		042519	SYSTEM UTILITIES-SAGE	4	04/25/2019	215.07	.00	215.07	15589	05/03/2019
		042519	SYSTEM UTILITIES-WELL	5	04/25/2019	1,659.82	.00	1,659.82	15589	05/03/2019
		042519	SYSTEM UTILITIES-SAGE	6	04/25/2019	8.85	.00	8.85	15589	05/03/2019
		042519	SYSTEM UTILITIES-SKYL	7	04/25/2019	10.50	.00	10.50	15589	05/03/2019
		042519	SYSTEM UTILITIES-ELKH	8	04/25/2019	29.36	.00	29.36	15589	05/03/2019
		042519	SYSTEM UTILITIES-REUS	9	04/25/2019	472.34	.00	472.34	15589	05/03/2019
		042519	SYSTEM UTILITIES-WELL	10	04/25/2019	412.07	.00	412.07	15589	05/03/2019
		042519	SYSTEM UTILITIES-WELL	11	04/25/2019	2,888.41	.00	2,888.41	15589	05/03/2019
		042519	SYSTEM UTILITIES-WELL	12	04/25/2019	159.52	.00	159.52	15589	05/03/2019
		042519	SYSTEM UTILITIES-WELL	13	04/25/2019	173.20	.00	173.20	15589	05/03/2019
		042519	SYSTEM UTILITIES-MCH	14	04/25/2019	144.01	.00	144.01	15589	05/03/2019
		042519	SYSTEM UTILITIES-ST LU	15	04/25/2019	270.78	.00	270.78	15589	05/03/2019
		042519	SYSTEM UTILITIES-LANE	16	04/25/2019	97.98	.00	97.98	15589	05/03/2019
		042519	SYSTEM UTILITIES-WELL	17	04/25/2019	737.04	.00	737.04	15589	05/03/2019
		042519	SYSTEM UTILITIES-DOLL	18	04/25/2019	8.53	.00	8.53	15589	05/03/2019
		042519	SYSTEM UTILITIES-WHIT	19	04/25/2019	7.75	.00	7.75	15589	05/03/2019
		042519	SYSTEM UTILITIES-SKYL	20	04/25/2019	88.65	.00	88.65	15589	05/03/2019
		042519	SYSTEM UTILITIES-47 LA	21	04/25/2019	447.83	.00	447.83	15589	05/03/2019
		042519	SYSTEM UTILITIES-49 LA	22	04/25/2019	334.66	.00	334.66	15589	05/03/2019
		042519	SYSTEM UTILITIES-SUN	23	04/25/2019	44.59	.00	44.59	15589	05/03/2019
		042519	SYSTEM UTILITIES-SAGE	24	04/25/2019	853.35	.00	853.35	15589	05/03/2019
		042519	SYSTEM UTILITIES-WELL	25	04/25/2019	463.52	.00	463.52	15589	05/03/2019
		042519	SYSTEM UTILITIES-WELL	26	04/25/2019	263.75	.00	263.75	15589	05/03/2019
		042519	SYSTEM UTILITIES-WELL	27	04/25/2019	543.89	.00	543.89	15589	05/03/2019
		042519	SYSTEM UTILITIES-WELL	28	04/25/2019	12.26	.00	12.26	15589	05/03/2019
		042519	SYSTEM UTILITIES-WELL	29	04/25/2019	121.88	.00	121.88	15589	05/03/2019
		042519	SYSTEM UTILITIES-WELL	30	04/25/2019	93.99	.00	93.99	15589	05/03/2019
		042519	SYSTEM UTILITIES-BACK	31	04/25/2019	42.33	.00	42.33	15589	05/03/2019
		042519	SYSTEM UTILITIES-SUN	32	04/25/2019	6.77	.00	6.77	15589	05/03/2019
Total 430:						11,297.75	.00	11,297.75		
451	INDEPENDENT AUTOMO	19788	AUTO R/M-2010 GMC TE	1	03/15/2019	158.68	.00	158.68	15567	04/15/2019
Total 451:						158.68	.00	158.68		

Vendor Number	Name	Invoice Number	Description	Seq	Invoice Date	Invoice Amount	Discount Amount	Check Amount	Check Number	Check Issue Date
460	Intermountain Gas Co	042419	SYSTEM UTILITIES-WELL	1	04/24/2019	18.77	.00	18.77	15590	05/03/2019
		042419	SYSTEM UTILITIES-SAGE	2	04/24/2019	9.79	.00	9.79	15590	05/03/2019
		042419	SYSTEM UTILITIES - 48 L	3	04/24/2019	140.08	.00	140.08	15590	05/03/2019
		042419	SYSTEM UTILITIES-1 BLA	4	04/24/2019	13.48	.00	13.48	15590	05/03/2019
		042419	SYSTEM UTILITIES-ELKH	5	04/24/2019	10.53	.00	10.53	15590	05/03/2019
		042419	SYSTEM UTILITIES-WELL	6	04/24/2019	14.01	.00	14.01	15590	05/03/2019
		042419	SYSTEM UTILITIES-MCH	7	04/24/2019	11.03	.00	11.03	15590	05/03/2019
		042419	SYSTEM UTILITIES-LANE	8	04/24/2019	11.90	.00	11.90	15590	05/03/2019
		042419	SYSTEM UTILITIES - REU	9	04/24/2019	10.85	.00	10.85	15590	05/03/2019
Total 460:						240.44	.00	240.44		
515	Ketchum, City of	033119	HEADWORKS PROJECT-	1	03/31/2019	146,190.40	.00	146,190.40	15553	04/15/2019
		033119	KSTP OPERATINGSMAR	2	03/31/2019	36,259.84	.00	36,259.84	15553	04/15/2019
Total 515:						182,450.24	.00	182,450.24		
570	Lutz Rentals	93153-1	BLDG R/M - 34' LIFT/TRAI	1	03/26/2019	244.35	.00	244.35	15569	04/15/2019
Total 570:						244.35	.00	244.35		
575	Magic Valley Labs, Inc	11601	H2O TEST FEES/MAR	1	03/29/2019	112.00	.00	112.00	15570	04/15/2019
Total 575:						112.00	.00	112.00		
581	PATRICK J MCMAHON	PAT030119	HEALTH INSURE EXP-PA	1	03/01/2019	480.78	.00	480.78	15573	04/15/2019
Total 581:						480.78	.00	480.78		
582	MAHLKE HUNSAKER & C	1-2072	2017-18 ANNUAL AUDIT	1	04/01/2019	1,935.00	.00	1,935.00	15571	04/15/2019
Total 582:						1,935.00	.00	1,935.00		
670	Pipeco Inc	030719	SEWER R/M - WHITE CLO	1	03/07/2019	2.03	.00	2.03	15574	04/15/2019
Total 670:						2.03	.00	2.03		
710	CENTURY LINK	040119	TELEPHONE EXP/MAR	1	04/01/2019	362.40	.00	362.40	15560	04/15/2019
		050119	TELEPHONE EXP/APR	1	05/01/2019	476.51	.00	476.51	15595	05/15/2019
Total 710:						838.91	.00	838.91		
735	River Run Auto Parts	6538-139328	AUTO R/M- WIPER BLAD	1	03/07/2019	14.99	.00	14.99	15575	04/15/2019
		6538-139421	SEWER R/M - MCHANVIL	1	03/12/2019	14.95	.00	14.95	15575	04/15/2019
Total 735:						29.94	.00	29.94		
741	J. EVAN ROBERTSON P.A	10947	ATTORNEY'S FEES - FEB	1	02/28/2019	6,755.00	.00	6,755.00	15552	04/15/2019
Total 741:						6,755.00	.00	6,755.00		
915	United Oil	906608	GAS & OIL EXPENSE-TH	1	03/15/2019	332.11	.00	332.11	15576	04/15/2019
		907745	GAS & OIL EXPENSE-TH	1	03/31/2019	188.55	.00	188.55	15576	04/15/2019
Total 915:						520.66	.00	520.66		
975	Verizon Wireless	9828599038	CELL PHONES-MAR 22-A	1	04/21/2019	191.36	.00	191.36	15591	05/03/2019

Vendor Number	Name	Invoice Number	Description	Seq	Invoice Date	Invoice Amount	Discount Amount	Check Amount	Check Number	Check Issue Date
Total 975:						191.36	.00	191.36		
1022	WELLS FARGO FINANCI	5008150698	COPIER LEASE- 4/5/19-5/	1	04/09/2019	232.56	.00	232.56	15586	04/22/2019
Total 1022:						232.56	.00	232.56		
1035	Wells Fargo Payment Remi	041519	TM&E-KNEADERY/STRBK	1	04/15/2019	67.37	.00	67.37	15587	04/22/2019
		041519	DUES/SUBSCRIPTIONS	2	04/15/2019	3.99	.00	3.99	15587	04/22/2019
Total 1035:						71.36	.00	71.36		
1037	Western States Equipment	IN000917693	SEWER R/M-GENERATO	1	03/12/2019	224.03	.00	224.03	15578	04/15/2019
Total 1037:						224.03	.00	224.03		
1088	ANDREW J NEUNER	030819	030819 SVCS	1	03/08/2019	188.27	.00	188.27	15555	04/15/2019
		032519 AN	032519 ZENERGY SPORT	1	03/25/2019	135.10	.00	135.10	15555	04/15/2019
Total 1088:						323.37	.00	323.37		
1093	JEANENE M PARKER	J PARKER 0	MEDICAL EXP 03/11/19	1	03/11/2019	59.92	.00	59.92	15568	04/15/2019
		JPARKER - 3	MEDICAL 3/11/19	1	03/11/2019	145.35	.00	145.35	15568	04/15/2019
Total 1093:						205.27	.00	205.27		
1103	COPY & PRINT LLC	95060	MASS PAPER SHREDDIN	1	02/19/2019	939.06	.00	939.06	15564	04/15/2019
		98127	PAPER SHREDDING	1	03/29/2019	21.18	.00	21.18	15564	04/15/2019
Total 1103:						960.24	.00	960.24		
1105	MCKENZIE, MELISSA	J MCKENZIE	JUSTIN 3/21/19	1	03/21/2019	18.22	.00	18.22	15572	04/15/2019
		MELISSA-03	HEALTH INS EXP THROU	1	03/25/2019	782.18	.00	782.18	15572	04/15/2019
Total 1105:						800.40	.00	800.40		
1106	WENDY KIRKPATRICK	033119	SVC 3/8-3/29/19	1	03/31/2019	1,087.50	.00	1,087.50	15577	04/15/2019
Total 1106:						1,087.50	.00	1,087.50		
1107	Idaho Bureau of Occupatio	MCKENZIE	APPLICATION/EXAM/LICE	1	04/17/2019	92.00	.00	92.00	15583	04/17/2019
Total 1107:						92.00	.00	92.00		
Grand Totals:						235,390.66	.00	235,390.66		

Report Criteria:

Detail report type printed

Prepared For	SUN VALLEY WATER PJ MCMAHON
Account Number	[REDACTED]
Statement Closing Date	04/12/19
Days in Billing Cycle	30
Next Statement Date	05/13/19

For 24-Hour Customer Service Call:
800-225-5935

Inquiries or Questions:
Wells Fargo SBL PO Box 29482
Phoenix, AZ 85038-8650

Payments:
Payment Remittance Center PO Box 77033
Minneapolis, MN 55480-7733

Credit Line	\$9,000
Available Credit	\$8,587

Payment Information

New Balance	\$71.36
Current Payment Due (Minimum Payment)	\$25.00
Current Payment Due Date	05/07/19

If you wish to pay off your balance in full: The balance noted on your statement is not the payoff amount. Please call 800-225-5935 for payoff information.

TME - 4-03-47 - 67.37
Dues/Sub - 4-03-48 - 3.99

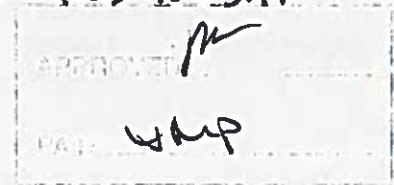

Account Summary

Previous Balance		\$600.19
Credits	-	\$0.00
Payments	-	\$600.19
Purchases & Other Charges	+	\$71.36
Cash Advances	+	\$0.00
Finance Charges	+	\$0.00
New Balance	=	\$71.36

Rate Information

Your rate may vary according to the terms of your agreement.

TYPE OF BALANCE	ANNUAL INTEREST RATE	DAILY FINANCE CHARGE RATE	AVERAGE DAILY BALANCE	PERIODIC FINANCE CHARGES	TRANSACTION FINANCE CHARGES	TOTAL FINANCE CHARGES
PURCHASES	20.490%	.05613%	\$0.00	\$0.00	\$0.00	\$0.00
CASH ADVANCES	25.240%	.07189%	\$0.00	\$0.00	\$0.00	\$0.00
TOTAL				\$0.00	\$0.00	\$0.00

Transaction Details

Trans	Post	Reference Number	Description	Credits	Charges
03/18	03/18	24717052E7JVWKA23	STARBUCKS KETCHUM ID		14.91
03/19	03/19	24592162E2Y159EMF	PANDORA*INTERNET RADIO PDORA.COM/BIL CA		3.99
03/25	03/25	24231682MLAR9YE2R	SUN VALLEY CORP F&B SUN VALLEY ID		52.45
03/29	03/29	74856202R26RZE9MK	PAYMENT THANK YOU	600.19	

See reverse side for important information.

5596 0013 YTG 1 7 7 190412 0 PAGE 1 of 4 10 5921 0100 BXG4 01005596 34419

DETACH HERE

Detach and mail with check payable to "Wells Fargo" to arrive by Current Payment Due Date.

Make checks payable to: Wells Fargo

Report Criteria:

Detail report.

Invoices with totals above \$5000.00 included.

Only unpaid invoices included.

Vendor Name = (NOT LIKE) "IDAHO POWER","INTERMOUNTAIN GAS","CASELLE INC.,""CENTURY LINK","COX BUSINESS SERVICES","IDAHO DEQ","Verizon Wireless","WELLS FARGO FINANCIAL LEASING","Wells Fargo Payment Remittance Ctr","AA TANKS CO"

GL Acct No	Vendor Name	Description	Net Invoice Amount
70			
4-02-31 OFFICE SUPPLIES			
	Banyan Technology Inc.	OFC SUPP - ADOBE ACROBAT PRO	559.00
4-03-63 R/M - WATER SYSTEM			
	Banyan Technology Inc.	H2O R/M - ANNUAL SERVICE AGREEMENT 4/1/19-4/1/20	6,940.00
4-03-70 R/M - REUSE SYSTEM			
	Banyan Technology Inc.	REUSE R/M - RE-USE LIFT STATION STARTUP - TUNE DRIVES	725.46
Total 70:			<u>8,224.46</u>
180			
1-68-00 FIXED ASSETS - W.I.P. - WATER			
	CH2M Hill INC.	ADMIN GENERAL CONSULTING WELL 13	18,082.27
4-03-63 R/M - WATER SYSTEM			
	CH2M Hill INC.	EQUIVILENT CONNECTION WORK	6,335.10
Total 180:			<u>24,417.37</u>
515			
1-69-00 FIXED ASSETS - W.I.P. - SEWER			
	Ketchum, City of	HEADWORKS PROJECT-ENVIRO-CARE/RSCI	114,445.97
4-03-40 KSTP OPERATIONS			
	Ketchum, City of	KSTP OPERATINGS/APRIL 2019	52,501.65
Total 515:			<u>166,947.62</u>
741			
4-03-43 ATTORNEY'S FEES			
	J. EVAN ROBERTSON P.A.	ATTORNEY'S FEES - APR	8,085.00
Total 741:			<u>8,085.00</u>
820			
4-01-24 WORKERS' COMPENSATION EXPENSE			
	State Insurance Fund	WORKMANS COMP 4/1/18-4/1/19	7,444.00
Total 820:			<u>7,444.00</u>
Grand Totals:			<u><u>215,118.45</u></u>

Report Criteria:

Deposit date: 4/18/2019
ACH file created: C:\Users\Joanne\Desktop\PAYROLL DIRECT DEPOSIT\ACHFILE41819.ach
Organization's offset record not included
Ordered by employee number

Employee Number	Name	Routing Number	Account Number	Type	Amount	Net Amount	Prenotice
3	Anderson, Anthony F.	123103729	153395134486	Checking Deposit	1,762.91	1,762.91	
4	Benson, Christopher N.	325070980	3087013409	Checking Deposit	1,670.49	1,670.49	
5	Neuner, Andrew J.	124103799	2323774337	Checking Deposit	1,523.75	1,523.75	
6	Springer, Daniel S.	124103582	918120041	Checking Deposit	2,100.04	2,100.04	
7	McMahon, Patrick J.	123103729	153354009554	Checking Deposit	2,642.87	2,642.87	
46	Parker, Jeanene	324173383	1400002058159	Checking Deposit	265.00	.00	
46	Parker, Jeanene	324173383	1010002058159	Savings Deposit	25.00	.00	
46	Parker, Jeanene	123171955	0813200018304	Checking Deposit	1,258.39	1,548.39	
47	McKenzie, Melissa S.	123103729	153353933200	Checking Deposit	1,406.14	1,406.14	

Total: 12,654.59-

Transaction count: 9
Debit total: .00
Credit total: 12,654.59-

APPROVED *[Signature]*
PAID *[Signature]*

Report Criteria

Deposit date 5/2/2019
ACH file created: C:\Users\Joanne\Desktop\PAYROLL DIRECT DEPOSIT\TACHFILE50219.ach
Organization's offset record not included
Ordered by employee number

Employee Number	Name	Routing Number	Account Number	Type	Amount	Net Amount	Prenotice
3	Anderson, Anthony F.	123103729	153395134486	Checking Deposit	1,820.51	1,820.51	
4	Benson, Christopher N.	325070980	3087013409	Checking Deposit	1,939.74	1,939.74	
5	Neuner, Andrew J.	124103799	2323774337	Checking Deposit	1,597.09	1,597.09	
6	Springer, Daniel S.	124103582	918120041	Checking Deposit	1,980.39	1,980.39	
7	McMahon, Patrick J.	123103729	153354009554	Checking Deposit	2,586.68	2,586.68	
46	Parker, Jeanene	324173383	1400002058159	Checking Deposit	265.00	.00	
46	Parker, Jeanene	324173383	1010002058159	Savings Deposit	25.00	.00	
46	Parker, Jeanene	123171955	0813200018304	Checking Deposit	1,298.39	1,588.39	
47	McKenzie, Melissa S.	123103729	153353933200	Checking Deposit	1,503.53	1,503.53	
Total:						<u>13,016.33-</u>	
Transaction count:		9					
Debit total:		.00					
Credit total:		13,016.33-					

OK
JMP

Sun Valley Water Capital Projects

2019 Fiscal Year Beginning Balance Dec Jan Feb Mar Apr YEAR END Ending Balance
 FROM 11/30/18 13TH MONTH ADDITIONS

Capital Water Projects	2017 Bitterroot Road	2005 Well #14/Trail Creek	2004 Well #13	2010 Meter	SVC0 EQ	PLC UPRGRADE	Auditors JE	2017 Bitterroot Road	2005 Well #14/Trail Creek	2004 Well#13	2010 Meter/CLOSE-REOPEN	White Cloaks
2017 Bitterroot Road	\$63,991.76	\$80,672.75						\$124,664.51				
2005 Well #14/Trail Creek	\$168,871.18							\$168,871.18				
2004 Well #13	\$1,623,580.55	\$5,810.01	2,692.82					\$1,650,165.65				
2010 Meter	\$9,204.35							\$9,204.35				
SVC0 EQ	45,131.80							\$45,131.80				
PLC UPRGRADE	16,565.39	\$1,083.48	\$25,618.99	\$19,472.47				\$62,740.33				
Auditors JE								\$0.00				
Total	1,927,345.03	\$87,566.24	26,311.81	19,472.47	0.00			2,060,777.82				

GL Acct 1.68 2018/19 CUMULATIVE WATER TOTAL \$67,566.24 \$95,878.05 \$115,350.52 \$115,350.52 \$133,432.79 \$133,432.79 \$133,432.79 YTD TOTAL FOR 2018/19

KSTP-ASSETS 1.96 11,800,798.23 11,800,798.23 YTD TOTAL FOR 2018/19

YTD TOTAL FOR 2018/19

Capital Sewer Projects	2018/19 CUMULATIVE SEWER TOTAL	2018/19 CUMULATIVE SEWER TOTAL	2018/19 CUMULATIVE SEWER TOTAL	2018/19 CUMULATIVE SEWER TOTAL	2018/19 CUMULATIVE SEWER TOTAL	2018/19 CUMULATIVE SEWER TOTAL	2018/19 CUMULATIVE SEWER TOTAL	2018/19 CUMULATIVE SEWER TOTAL	2018/19 CUMULATIVE SEWER TOTAL	2018/19 CUMULATIVE SEWER TOTAL	2018/19 CUMULATIVE SEWER TOTAL	2018/19 CUMULATIVE SEWER TOTAL
KSTP-Headworks/Screen Project	\$921,502.99	\$136,827.20	\$155,142.63	\$83,780.59	\$146,190.40	\$114,445.97	\$0.00	\$1,557,889.78				
Total	\$921,502.99	\$136,827.20	\$155,142.63	\$83,780.59	\$146,190.40	\$114,445.97	\$0.00	\$1,557,889.78				

GL Acct 1.69 2018/19 CUMULATIVE SEWER TOTAL \$136,827.20 \$291,969.83 \$375,750.42 \$521,940.82 \$636,386.79 \$636,386.79 \$636,386.79

Monthly Total 2,948,848.02 204,393.44 183,454.44 103,253.06 146,190.40 132,528.24 0.00 \$3,339,948.96

Cumulative Total \$204,393.44 \$387,847.88 \$491,100.94 \$637,291.34 \$769,819.58

KSTP Headworks/Screen Project

Terminated 236 Vendors

Report Criteria:

Vendor Termination date is null

Vendor #	Name	Last Check Date	YTD Payments
6	ALPINE TREE SERVICE	07/14/2017	.00
22	AMERIGAS	04/10/2017	.00
25	Analytical Laboratories, Inc.	06/14/2018	.00
30	Anderson Asphalt Paving	11/15/2018	.00
35	Anderson, Anthony	04/15/2019	377.01
50	Atkinson's Market	03/18/2019	1,334.53
60	AWWA	09/17/2018	.00
61	PNWS-AWWA	01/15/2019	100.00
70	Banyan Technology Inc.	03/18/2019	45,791.28
85	Benchmark Associates	09/17/2018	.00
90	Benson, Chris	04/15/2019	163.42
106	BISNETT INSURANCE INC.	02/09/2018	.00
111	BLAINE COUNTY CLERK		.00
112	BLAINE COUNTY P & Z		.00
113	BLAINE COUNTY EXTENSION	02/20/2015	.00
120	Blue Cross Of Idaho	10/19/2017	.00
125	Blue Printing	05/09/2016	.00
126	BOISE OFFICE EQUIPMENT	04/15/2019	617.01
127	BOLEN'S CONTROL HOUSE INC.	04/15/2019	693.39
145	Brooks Welding	09/17/2018	.00
160	BUREAU OF OCCUPATIONAL LICENSE	02/19/2019	60.00
165	BURKS EXCAVATION CORP OF IDAHO	03/27/2019	2,486.98
170	Business As Usual	04/15/2019	1,688.35
175	CASELLE INC.	04/15/2019	2,444.00
180	CH2M Hill INC.	04/15/2019	18,853.02
185	Chateau Drug	04/15/2019	98.02
186	CINTAS CORPORATION	03/06/2018	.00
190	Clear Creek Disposal	04/15/2019	41.81
193	CLEAR WATER ROBOTICS		.00
205	Color Haus	04/15/2019	150.66
213	CONRAD BROTHERS OF IDAHO, INC.	03/27/2019	633.50
215	Consolidated Supply Co.	06/14/2018	.00
220	COX BUSINESS SERVICES	04/22/2019	356.00
222	Crum Electric Supply Co.		.00
223	CUMMINS ROCKY MOUNTAIN LLC	04/10/2017	.00
235	D AND L SUPPLY	07/13/2018	.00
237	Data Tel Communications	03/18/2019	734.95
245	Davis Embroidery	11/15/2018	.00
254	DELTA DENTAL OF IDAHO	08/17/2017	.00
260	Dept Of Environmental Quality		.00
270	Dig Line Inc	04/15/2019	285.40
273	DIVISION OF BUILDING SAFETY	12/04/2018	.00
275	EC Power Systems Of Idaho		.00
286	EGGERS ASSOCIATES P.A.	07/14/2017	.00
288	ELEVATION GARAGE DOORS LLC	02/10/2017	.00
295	Federal Express		.00
297	FERGUSON ENTERPRISES LLC #3007	04/15/2019	3,775.39
300	Fini Machinery Inc.	05/17/2018	.00
305	Fire Services of Idaho Inc	02/19/2019	496.50
310	F-Stop	10/15/2014	.00
315	G C Systems Inc	09/17/2018	.00
320	Galena Engineering Inc		.00
321	GALENA GROUND WATER DISTRICT	12/17/2018	.00
325	Garrett Construction Inc		.00
333	GRAINGER	02/19/2019	172.50
347	Hawkins & Company	10/08/2018	.00

Vendor #	Name	Last Check Date	YTD Payments
351	HIGH COUNTRY NEWS	11/15/2017	.00
365	Houston Lumber Co.	04/15/2019	233.44
385	Humphrey, Joseph K.		.00
390	Hunter Landscape, Inc.	12/17/2018	.00
398	IDAHO CHAPTER OF IA EI		.00
400	Icma Retirement Trust - 457	10/19/2017	.00
405	ICRMP	04/22/2019	18,919.50
409	IDAHO DEQ	03/18/2019	908.00
410	Idaho Dept. Of Labor		.00
415	IDAHO DEPART OF WATER RESOURCE		.00
420	Idaho Lumber		.00
425	EXPRESS PUBLISHING INC.	09/17/2018	.00
429	IDAHO POWER	08/17/2017	.00
430	Idaho Power	05/03/2019	59,411.42
435	IDAHO RURAL WATER ASSOCIATION	07/19/2018	.00
440	Idaho State Tax Commission	09/19/2017	.00
441	IDAHO STATE TREASURER'S OFFICE		.00
443	IDAHO WATER USERS ASSOCIATION	01/09/2018	.00
451	INDEPENDENT AUTOMOTIVE SERVICE,	04/15/2019	511.58
457	INTERMOUNTAIN AUTO GLASS INC		.00
460	Intermountain Gas Co	05/03/2019	1,884.20
465	Interstate Electric Supply		.00
470	ISPWC	04/17/2015	.00
480	IWWOCB Inc		.00
490	Joe's Backhoe Service, Inc.	12/17/2018	.00
515	Ketchum, City of	04/15/2019	654,464.58
521	KOLMAN CONCRETE INC.	08/10/2018	.00
530	Lab Safety Supply Inc		.00
540	Layne Pumps Inc	12/17/2018	.00
548	LES SCHWAB TIRE CENTER	09/17/2018	.00
550	MATTHEW BENDER & CO., INC	09/17/2018	.00
565	Loyd, James D.		.00
567	LUNCEFORD EXCAVATION INC.	11/15/2017	.00
570	Lutz Rentals	04/15/2019	312.39
575	Magic Valley Labs, Inc	04/15/2019	390.00
576	MATERIALS TESTING & INSPECTION	08/31/2017	.00
577	Mattson Fire Sprinklers, Inc.	08/15/2018	.00
578	MC COY'S PAINTING	08/15/2018	.00
581	PATRICK J MCMAHON	04/15/2019	814.38
582	MAHLKE HUNSAKER & CO, PLLC	04/15/2019	6,715.00
620	MUELLER SYSTEMS	12/17/2018	.00
624	H. D. FOWLER COMPANY	07/14/2017	.00
630	National Waterworks Inc.		.00
636	NEUNER, ANDY	03/18/2019	418.31
655	Ohio Gulch Transfer Station	10/08/2018	.00
670	Pipeco Inc	04/15/2019	37.18
677	PLATT ELECTRIC SUPPLY, INC	01/15/2019	97.56
680	Pollardwater	11/15/2018	.00
700	Public Employee Retirement Sys	09/19/2017	.00
710	CENTURY LINK	05/15/2019	2,392.04
735	River Run Auto Parts	04/15/2019	538.57
737	ROAD WORK AHEAD CONSTRUCTION		.00
741	J. EVAN ROBERTSON P.A.	04/15/2019	26,740.00
745	MARCO ROMERO COMPUTER SERVIC	02/19/2019	1,159.00
755	S. Erwin Excavation Inc.		.00
770	Sawtooth Paint & Airless		.00
772	SAWTOOTH WOOD PRODUCTS, INC		.00
785	Severn Trent Service		.00

Vendor #	Name	Last Check Date	YTD Payments
795	SILVER CREEK SUPPLY	06/14/2017	.00
798	SKINNER FAWCETT		.00
805	SPARLING INSTRUMENTS, LLC	05/12/2017	.00
806	DANIEL S. SPRINGER	06/28/2018	.00
810	Standard Insurance Co	10/05/2017	.00
815	Standard Insurance Fund		.00
816	STANDARD PLUMBING SUPPLY CO.	10/08/2018	.00
820	State Insurance Fund	05/17/2018	.00
830	Stock Building Supply		.00
835	Sun Valley Company		.00
837	SUN VALLEY ELKHORN ASSOCIATION	11/14/2016	.00
845	Sun Valley Title		.00
855	CITY OF SUN VALLEY	01/08/2019	60,672.75
886	THE WATER REPORT	08/23/2018	.00
890	Thomton Heat & Sheetmetal Inc	06/14/2018	.00
895	U.S. Postal Service	03/18/2019	204.00
915	United Oil	04/15/2019	2,549.04
920	United Parcel Service		.00
925	United Pipe & Supply		.00
927	UNITED STATES TREASURY	01/09/2019	1.82
935	USA Blue Book	11/15/2018	.00
975	Verizon Wireless	05/03/2019	958.11
1005	Walton, Douglas	11/15/2018	.00
1011	WATER DISTRICT 37	02/19/2019	2,169.97
1020	WELLS FARGO BANK, N.A.		.00
1021	Wells Fargo Bank	08/15/2018	.00
1022	WELLS FARGO FINANCIAL LEASING	04/22/2019	930.24
1030	Wells Fargo Business Credit		.00
1035	Wells Fargo Payment Remittance Ctr	04/22/2019	3,495.70
1035	Wells Fargo Payment Remittance Ctr	04/22/2019	3,495.70
1036	WELLS FARGO BROKERAGE SER. LLC		.00
1037	Western States Equipment	04/15/2019	224.03
1044	WHITEHEAD LANDSCAPING INC.	08/15/2018	.00
1060	WOOD RIVER LOCK LLC	03/26/2019	4.00
1078	XEROX CORPORATION		.00
1081	ZIONS BANK PUBLIC FINANCE		.00
1083	ZIONS FIRST NATIONAL BANK	06/14/2018	.00
1083	ZIONS FIRST NATIONAL BANK	06/14/2018	.00
1088	ANDREW J NEUNER	04/15/2019	323.37
1090	WIN-911	12/08/2017	.00
1091	MAXWELL STRUCTURAL DESIGN STU	02/19/2019	4,322.50
1092	IDAHO WATER UTILITIES COUNCIL	01/09/2018	.00
1093	JEANENE M PARKER	04/15/2019	1,017.00
1095	CUSTOMER - REFUND	11/06/2018	.00
1095	CUSTOMER - REFUND	11/06/2018	.00
1095	CUSTOMER - REFUND	11/06/2018	.00
1095	CUSTOMER - REFUND	11/06/2018	.00
1098	FARMER BROTHERS COFFEE	02/19/2019	102.90
1099	IMPACT AUTO BODY	10/12/2018	.00
1101	INTEGRITY INSPECTION SOLUTIONS, I	11/15/2018	.00
1102	AMERICAN LEAK DETECTION	11/15/2018	.00
1103	COPY & PRINT LLC	04/15/2019	960.24
1104	Wood River RC&D	03/06/2019	116.16
1105	MCKENZIE, MELISSA	04/15/2019	1,138.22
1106	WENDY KIRKPATRICK	04/15/2019	1,087.50
1107	Idaho Bureau of Occupational Licences	04/17/2019	92.00

**SUN VALLEY WATER AND SEWER DISTRICT
SEWER TREATMENT PLANT OPERATIONAL EXPENSES**

MONTH ENDING: April 2019

CHECK #	IN FAVOR OF:	DATE	STP CHARGE	SUN VALLEY 44.13%	DESCRIPTION
	SEE ATTACHED	12/31	\$ 63,847.41	\$ 29,058.46	
	Payroll	12/31	\$ 29,054.78	\$ 12,821.87	
	Retirement	12/31	\$ 3,289.00	\$ 1,451.44	
	FICA	12/31	\$ 2,222.69	\$ 980.87	
	Health Insurance	12/31	\$ 15,684.75	\$ 6,921.68	
	Dental Insurance	12/31	\$ 391.55	\$ 172.79	
	Long Term Disability	12/31	\$ 124.12	\$ 54.77	
	NBS - HRA Admin Fees	12/31	\$ 29.94	\$ 13.21	
	Insurance Admin Fees	12/31	\$ 59.63	\$ 26.31	
	NBS - HRA for 2019	12/31	\$ 469.07	\$ 207.00	
	NBS - Vision HRA for 2019	12/31	\$ 1,489.97	\$ 657.52	
**	Worker's Compensation	12/31	\$ 307.52	\$ 135.71	
TOTALS			\$ 118,970.43	\$ 52,501.65	

KETCHUM PERCENT	55.87%
KETCHUM DOLLAR SHARE	\$ 66,468.78
SUN VALLEY PERCENT	44.13%
SUN VALLEY DOLLAR SHARE	\$ 52,501.65

TOTAL DUE \$ 52,501.65

Capital	Expense	50%
Enviro Care Co.	\$ 10,100.00	
Enviro Care Co.	\$ 10,100.00	
RSCI	\$ 208,691.94	
	<u>\$ 228,891.94</u>	\$ 114,445.97

Actual Total Due \$166,947.62

1-29-00 - \$114,445.97
4-03-40 - \$52,501.65
JK

APPLICATION AND CERTIFICATE FOR PAYMENT

DOCUMENT SUMMARY SHEET

TO OWNER/CLIENT:
 City of Ketchum
 480 East Ave. N
 Ketchum, Idaho 83340

PROJECT:
 505 - Ketchum/SVWSD Headworks Improvements
 110 River Ranch Road
 Ketchum, Idaho 83340

FROM CONTRACTOR:
 RSCI
 333 West Ross Street, Ste. 200
 Boise, Idaho 83706

VIA ARCHITECT/ENGINEER:
 Brad Bjork (HDR)
 412 Parkcenter Blvd Suite 400
 Boise, ID 83706

APPLICATION NO: 11
INVOICE NO: 11
PERIOD: 03/01/19 - 03/31/19
PROJECT NO: 505
CONTRACT DATE: 05/21/2018

DISTRIBUTION TO

CONTRACT FOR: 505 - Ketchum/SVWSD Headworks Improvements Prime Contract
CONTRACTOR'S APPLICATION FOR PAYMENT

Application is made for payment, as shown below, in connection with the Contract. Continuation Sheet is attached

- 1 Original Contract Sum \$ 2,481,360.00
- 2 Net change by change orders (\$56,185.74)
- 3 Contract sum to date (Line 1 ± 2): \$ 2,425,174.26
- 4 Total completed and stored to date (Column G on G703) \$ 2,200,355.58
- 5. Retainage:
 - a. 2.99% of completed work: \$ 64,889.26
 - b. 0.00% of stored material: \$ 0.00
- 6 Total retainage (Line 5a + 5b or total in column I of G702) \$ 64,889.26
- 7 Less previous certificates for payment (Line 4 less Line 5 Total) \$ 2,135,468.32
- 8 Current payment due \$ 1,926,774.38
- 9 Balance to finish, including retainage (Line 3 less Line 6) \$ 208,691.94

CONTRACTOR: RSCI

By: 
 State of Idaho
 County of Ada

Date: 04/05/2019

Subscribed and sworn to before me this 5 day of April 2019

Notary Public 
 My commission expires: 6-30-19
 VENETA R. MILL
 NOTARY PUBLIC - STATE OF IDAHO
 COMMISSION NUMBER 01776
 MY COMMISSION EXPIRES 6-30-2019

ARCHITECT'S/ENGINEER'S CERTIFICATE FOR PAYMENT

In accordance with the Contract Documents based on the on-site observations and the data comprising this application, the Architect/Engineer certifies to the Owner/Client that to the best of the Architect's/Engineer's knowledge, information and belief that Work is in accordance with the Contract Documents, and the Contractor is entitled to payment of the AMOUNT CERTIFIED.

AMOUNT CERTIFIED:

\$ 208,691.94

(Attach explanation if amount certified differs from the amount applied for. Initial all figures on this Application and on the Continuation Sheet that are changed to confirm to the amount certified)

ARCHITECT/ENGINEER
 By: 

Date: 04/05/2019

This certificate is non-negotiable. The amount certified is payable only to the contract named herein. Issuance, payment and acceptance of payment are without prejudice to the rights of the Owner/Client or Contractor under the Contract.

CHANGE ORDER SUMMARY	ADDITIONS	DEDUCTIONS
Total changes approved in previous months by Owner/Client:	\$ 59,772.96	(\$149,370.88)
Total approved this Month	\$ 35,638.58	(\$2,226.60)
Totals:	\$ 95,411.54	(\$151,597.28)
Net change by change orders.		(\$56,185.74)

Document G702, APPLICATION AND CERTIFICATE FOR PAYMENT, containing Contractor's signed Certification is attached.
Use Column I on Contracts where variable retainage for line items apply.

APPLICATION NUMBER: 11
APPLICATION DATE: 03/27/2019
PERIOD: 03/01/19 - 03/31/19
ARCHITECTS/ENGINEERS PROJECT NO:

Contract Lines

A ITEM NO.	B DESCRIPTION OF WORK	C SCHEDULED VALUE	D WORK COMPLETED		E THIS PERIOD	F MATERIALS PRESENTLY STORED (NOT IN D OR E)	G TOTAL COMPLETED AND STORED TO DATE (D+E+F)	H % (G / C)	I BALANCE TO FINISH (C - G)	RETAINAGE
			FROM PREVIOUS APPLICATION (D + E)							
1	ADMIN Mobilize	\$ 59,500.00	\$ 59,500.00	\$ 0.00	\$ 0.00	\$ 0.00	\$ 59,500.00	100.00%	\$ 0.00	\$ 2,975.00
2	ADMIN Performance & Payment Bonds	\$ 20,850.00	\$ 20,850.00	\$ 0.00	\$ 0.00	\$ 0.00	\$ 20,850.00	100.00%	\$ 0.00	\$ 1,042.50
3	ADMIN DIV 01/ Contract Submittals	\$ 36,047.00	\$ 34,244.65	\$ 1,081.41	\$ 0.00	\$ 0.00	\$ 35,326.06	98.00%	\$ 720.94	\$ 1,441.90
4	DEMO Demo Site Asphalt	\$ 16,800.00	\$ 16,800.00	\$ 0.00	\$ 0.00	\$ 0.00	\$ 16,800.00	100.00%	\$ 0.00	\$ 840.00
5	DEMO Demo Screen Building	\$ 25,200.00	\$ 25,200.00	\$ 0.00	\$ 0.00	\$ 0.00	\$ 25,200.00	100.00%	\$ 0.00	\$ 1,260.00
6	DEMO Demo UG Pipe	\$ 36,400.00	\$ 36,400.00	\$ 0.00	\$ 0.00	\$ 0.00	\$ 36,400.00	100.00%	\$ 0.00	\$ 1,820.00
7	DEMO Demo Existing Bar Rack	\$ 3,500.00	\$ 3,500.00	\$ 0.00	\$ 0.00	\$ 0.00	\$ 3,500.00	100.00%	\$ 0.00	\$ 175.00
8	SITE Chain Link Fence	\$ 6,800.00	\$ 0.00	\$ 0.00	\$ 0.00	\$ 0.00	\$ 0.00	0.00%	\$ 6,800.00	\$ 0.00
9	SITE Boilards	\$ 2,980.00	\$ 0.00	\$ 0.00	\$ 0.00	\$ 0.00	\$ 0.00	0.00%	\$ 2,980.00	\$ 0.00
10	SITE Site Grading	\$ 3,750.00	\$ 0.00	\$ 0.00	\$ 0.00	\$ 0.00	\$ 0.00	0.00%	\$ 3,750.00	\$ 0.00
11	SITE Base Course	\$ 15,600.00	\$ 0.00	\$ 0.00	\$ 0.00	\$ 0.00	\$ 0.00	0.00%	\$ 15,600.00	\$ 0.00
12	SITE Underground Electrical	\$ 26,500.00	\$ 25,175.00	\$ 0.00	\$ 0.00	\$ 0.00	\$ 25,175.00	95.00%	\$ 1,325.00	\$ 0.00
13	HW Splitter Box Structural Excavation	\$ 13,650.00	\$ 13,650.00	\$ 0.00	\$ 0.00	\$ 0.00	\$ 13,650.00	100.00%	\$ 0.00	\$ 682.50
14	HW Splitter Box Structural Fill	\$ 7,540.00	\$ 7,540.00	\$ 0.00	\$ 0.00	\$ 0.00	\$ 7,540.00	100.00%	\$ 0.00	\$ 377.00
15	HW Splitter Box Concrete Base Slab	\$ 44,100.00	\$ 44,100.00	\$ 0.00	\$ 0.00	\$ 0.00	\$ 44,100.00	100.00%	\$ 0.00	\$ 2,205.00
16	HW Splitter Box Concrete Walls	\$ 63,600.00	\$ 63,600.00	\$ 0.00	\$ 0.00	\$ 0.00	\$ 63,600.00	100.00%	\$ 0.00	\$ 3,180.00
17	HW Splitter Box Grating & Embeds	\$ 19,500.00	\$ 19,500.00	\$ 0.00	\$ 0.00	\$ 0.00	\$ 19,500.00	100.00%	\$ 0.00	\$ 731.25
18	HW Splitter Box Wall Spools	\$ 84,500.00	\$ 84,500.00	\$ 0.00	\$ 0.00	\$ 0.00	\$ 84,500.00	100.00%	\$ 0.00	\$ 4,225.00
19	HW Gates SG-111 & SG-112	\$ 49,400.00	\$ 46,930.00	\$ 2,470.00	\$ 0.00	\$ 0.00	\$ 49,400.00	100.00%	\$ 0.00	\$ 1,852.50
20	HW Screen Channel Excavation	\$ 24,700.00	\$ 24,700.00	\$ 0.00	\$ 0.00	\$ 0.00	\$ 24,700.00	100.00%	\$ 0.00	\$ 1,235.00
21	HW Screen Channel Structural Fill	\$ 17,680.00	\$ 17,680.00	\$ 0.00	\$ 0.00	\$ 0.00	\$ 17,680.00	100.00%	\$ 0.00	\$ 884.00
22	HW Screen Channel Concrete Slab	\$ 56,800.00	\$ 56,800.00	\$ 0.00	\$ 0.00	\$ 0.00	\$ 56,800.00	100.00%	\$ 0.00	\$ 2,840.00
23	HW Screen Channel Concrete Walls	\$ 85,950.00	\$ 85,950.00	\$ 0.00	\$ 0.00	\$ 0.00	\$ 85,950.00	100.00%	\$ 0.00	\$ 4,297.50
24	HW Screen Channel Grating & Embeds	\$ 32,500.00	\$ 29,250.00	\$ 1,625.00	\$ 0.00	\$ 0.00	\$ 30,875.00	95.00%	\$ 1,625.00	\$ 1,218.75

CONTINUATION SHEET

A ITEM NO.	B DESCRIPTION OF WORK	C SCHEDULED VALUE	E WORK COMPLETED		F MATERIALS PRESENTLY STORED (NOT IN D OR E)	G TOTAL COMPLETED AND STORED TO DATE (D+E+F)	H % (G / C)	BALANCE TO FINISH (C - G)	I RETAINAGE
			D FROM PREVIOUS APPLICATION (D + E)	THIS PERIOD					
25	HW Screen Channel	\$ 16,900.00	\$ 16,900.00	\$ 0.00	\$ 0.00	\$ 16,900.00	100.00%	\$ 0.00	\$ 845.00
26	HW CLSM Fill	\$ 56,550.00	\$ 56,550.00	\$ 0.00	\$ 0.00	\$ 56,550.00	100.00%	\$ 0.00	\$ 2,827.50
27	HW Backfill	\$ 20,150.00	\$ 20,150.00	\$ 0.00	\$ 0.00	\$ 20,150.00	100.00%	\$ 0.00	\$ 1,007.50
28	HW Building Concrete Footings	\$ 37,400.00	\$ 37,400.00	\$ 0.00	\$ 0.00	\$ 37,400.00	100.00%	\$ 0.00	\$ 1,870.00
29	HW Building Concrete Stem Walls	\$ 37,400.00	\$ 37,400.00	\$ 0.00	\$ 0.00	\$ 37,400.00	100.00%	\$ 0.00	\$ 1,870.00
30	HW Electrical Room Elevated Concrete Slab	\$ 22,400.00	\$ 22,400.00	\$ 0.00	\$ 0.00	\$ 22,400.00	100.00%	\$ 0.00	\$ 784.00
31	HW Masonry	\$ 136,500.00	\$ 136,500.00	\$ 0.00	\$ 0.00	\$ 136,500.00	100.00%	\$ 0.00	\$ 5,460.00
32	HW EIFS	\$ 36,400.00	\$ 0.00	\$ 0.00	\$ 0.00	\$ 0.00	0.00%	\$ 36,400.00	\$ 0.00
33	HW Concrete Slab on Grade	\$ 46,800.00	\$ 46,800.00	\$ 0.00	\$ 0.00	\$ 46,800.00	100.00%	\$ 0.00	\$ 0.00
34	HW Exterior Concrete Slabs & Pads	\$ 18,000.00	\$ 5,400.00	\$ 0.00	\$ 0.00	\$ 5,400.00	30.00%	\$ 12,600.00	\$ 0.00
35	HW Steel Deck & Joists	\$ 22,000.00	\$ 22,000.00	\$ 0.00	\$ 0.00	\$ 22,000.00	100.00%	\$ 0.00	\$ 0.00
36	HW Roofing	\$ 45,000.00	\$ 42,750.00	\$ 0.00	\$ 0.00	\$ 42,750.00	95.00%	\$ 2,250.00	\$ 0.00
37	HW Overhead Rolling Doors	\$ 28,000.00	\$ 10,244.00	\$ 0.00	\$ 16,356.00	\$ 28,600.00	95.00%	\$ 1,400.00	\$ 0.00
38	HW Doors & Hardware	\$ 12,500.00	\$ 0.00	\$ 0.00	\$ 0.00	\$ 0.00	0.00%	\$ 12,500.00	\$ 0.00
39	HW Owner Furnished Equipment Install	\$ 26,500.00	\$ 23,850.00	\$ 2,650.00	\$ 0.00	\$ 26,500.00	100.00%	\$ 0.00	\$ 0.00
40	HW Lighting	\$ 35,000.00	\$ 0.00	\$ 0.00	\$ 0.00	\$ 0.00	0.00%	\$ 35,000.00	\$ 0.00
41	HW Set Electrical Gear & Distribution	\$ 37,400.00	\$ 33,660.00	\$ 1,870.00	\$ 0.00	\$ 35,530.00	95.00%	\$ 1,870.00	\$ 0.00
42	HW Fire Alarm System	\$ 32,600.00	\$ 0.00	\$ 19,560.00	\$ 0.00	\$ 19,560.00	60.00%	\$ 13,040.00	\$ 0.00
43	HW Process Instrumentation & Controls	\$ 78,900.00	\$ 0.00	\$ 48,660.00	\$ 14,460.00	\$ 63,120.00	80.00%	\$ 15,780.00	\$ 0.00
44	HW Conduit & Raceways	\$ 137,800.00	\$ 124,020.00	\$ 6,890.00	\$ 0.00	\$ 130,910.00	95.00%	\$ 6,890.00	\$ 0.00
45	HW Conductors & Terminations	\$ 98,000.00	\$ 19,600.00	\$ 49,000.00	\$ 0.00	\$ 68,600.00	70.00%	\$ 29,400.00	\$ 0.00
46	HW Plumbing	\$ 51,500.00	\$ 51,500.00	\$ 0.00	\$ 0.00	\$ 51,500.00	100.00%	\$ 0.00	\$ 0.00
47	HW HVAC	\$ 140,000.00	\$ 126,000.00	\$ 7,000.00	\$ 0.00	\$ 133,000.00	95.00%	\$ 7,000.00	\$ 0.00
48	HW ODA Fiberglass Duct Work	\$ 110,000.00	\$ 88,000.00	\$ 16,500.00	\$ 0.00	\$ 104,500.00	95.00%	\$ 5,500.00	\$ 0.00
49	HW Coalings	\$ 35,000.00	\$ 3,500.00	\$ 29,750.00	\$ 0.00	\$ 33,250.00	95.00%	\$ 1,750.00	\$ 0.00
50	YARD Temporary Bypass Piping	\$ 105,000.00	\$ 105,000.00	\$ 0.00	\$ 0.00	\$ 105,000.00	100.00%	\$ 0.00	\$ 5,250.00
51	YARD 24" Sewer	\$ 24,080.00	\$ 24,080.00	\$ 0.00	\$ 0.00	\$ 24,080.00	100.00%	\$ 0.00	\$ 1,204.00
52	YARD 18" Sewer	\$ 53,240.00	\$ 53,240.00	\$ 0.00	\$ 0.00	\$ 53,240.00	100.00%	\$ 0.00	\$ 2,662.00
53	YARD 2" W2	\$ 45,080.00	\$ 45,080.00	\$ 0.00	\$ 0.00	\$ 45,080.00	100.00%	\$ 0.00	\$ 2,254.00
54	YARD 12" ODA	\$ 21,680.00	\$ 21,680.00	\$ 0.00	\$ 0.00	\$ 21,680.00	100.00%	\$ 0.00	\$ 1,084.00
55	YARD 4" Drain	\$ 14,600.00	\$ 14,600.00	\$ 0.00	\$ 0.00	\$ 14,600.00	100.00%	\$ 0.00	\$ 730.00

A ITEM NO.	B DESCRIPTION OF WORK	C SCHEDULED VALUE	D WORK COMPLETED		E THIS PERIOD	F MATERIALS PRESENTLY STORED (NOT IN D OR E)	G TOTAL COMPLETED AND STORED TO DATE (D+E+F)	H % (G / C)	I RETAINAGE
			FROM PREVIOUS APPLICATION (D + E)	THIS PERIOD					
56	VE Pre-award Value Engineering Items	\$ 145,133.00	\$ 145,133.00	\$ 0.00	\$ 0.00	\$ 0.00	\$ 145,133.00	100.00%	\$ 0.00
	TOTALS:	\$ 2,481,360.00	\$ 2,049,308.65	\$ 187,056.41		\$ 30,816.00	\$ 2,267,179.06	91.37%	\$ 214,180.94
									\$ 61,130.90

Whole Change Order Packages

A ITEM NO.	B DESCRIPTION OF WORK	C SCHEDULED VALUE	D WORK COMPLETED		E THIS PERIOD	F MATERIALS PRESENTLY STORED (NOT IN D OR E)	G TOTAL COMPLETED AND STORED TO DATE (D+E+F)	H % (G / C)	I RETAINAGE
			FROM PREVIOUS APPLICATION (D + E)	THIS PERIOD					
57	PCCO#001								
57.1	COR#001 Pre-award Value Engineering	(\$145,133.00)	(\$145,133.00)	\$ 0.00	\$ 0.00	\$ 0.00	(\$145,133.00)	100.00%	\$ 0.00
58	PCCO#002								
58.1	COR#004 Engineer's Office Trailer	(\$2,250.00)	(\$2,250.00)	\$ 0.00	\$ 0.00	\$ 0.00	(\$2,250.00)	100.00%	(\$12.50)
58.2	COR#007 RFI-011 - Thicker Slab Encountered at Existing Screen Building	\$ 4,483.00	\$ 4,483.00	\$ 0.00	\$ 0.00	\$ 0.00	\$ 4,483.00	100.00%	\$ 224.15
58.3	COR#005 RFI-007 - Asbestos Containing Material Encountered 15" Pipe	\$ 4,003.00	\$ 4,003.00	\$ 0.00	\$ 0.00	\$ 0.00	\$ 4,003.00	100.00%	\$ 200.15
58.4	COR#011 RFI-014 - Flume Manhole Concrete	\$ 6,350.00	\$ 6,350.00	\$ 0.00	\$ 0.00	\$ 0.00	\$ 6,350.00	100.00%	\$ 317.50
58.5	COR#013 RFI-018 - Concrete Mass at Screen Channel	\$ 4,522.00	\$ 4,522.00	\$ 0.00	\$ 0.00	\$ 0.00	\$ 4,522.00	100.00%	\$ 226.10
58.6	COR#015 Work Change Directive No. 004 - Plumbing Piping Changes	\$ 4,428.00	\$ 4,428.00	\$ 0.00	\$ 0.00	\$ 0.00	\$ 4,428.00	100.00%	\$ 0.00
59	PCCO#003								
59.1	COR#012 RFI-015 - Existing 24" Pipe Alignment Corrections	\$ 2,323.00	\$ 2,323.00	\$ 0.00	\$ 0.00	\$ 0.00	\$ 2,323.00	100.00%	\$ 116.15
59.2	COR#017 Work Change Directive No. 005 - Increase CMU Wall Height by 24"	\$ 10,387.00	\$ 10,387.00	\$ 0.00	\$ 0.00	\$ 0.00	\$ 10,387.00	100.00%	\$ 518.35
59.3	COR#020 RFI-020 - Plug Existing 24" Diameter Pipe Penetration at Pump Station	\$ 2,209.00	\$ 2,209.00	\$ 0.00	\$ 0.00	\$ 0.00	\$ 2,209.00	100.00%	\$ 110.45
59.4	COR#009 Work Change Directive No. 003 - ODA Revisions	\$ 9,047.00	\$ 9,047.00	\$ 0.00	\$ 0.00	\$ 0.00	\$ 9,047.00	100.00%	\$ 452.36
59.5	COR#022 RFI-024 - Delete Hose Reels and Add Hose Racks	(\$1,378.00)	(\$1,378.00)	\$ 0.00	\$ 0.00	\$ 0.00	(\$1,378.00)	100.00%	(\$68.90)

A ITEM NO.	B DESCRIPTION OF WORK	C SCHEDULED VALUE	D WORK COMPLETED		E THIS PERIOD	F MATERIALS PRESENTLY STORED (NOT IN D OR E)	G TOTAL COMPLETED AND STORED TO DATE (D+E+F)	H % (G / C)	I BALANCE TO FINISH (C - G)	I RETAINAGE
			FROM PREVIOUS APPLICATION (D + E)	THIS PERIOD						
59.6	COR#019 Design, Fabricate, & Install 316 SS Mounting Bracket Extensions	\$ 4,677.00	\$ 4,677.00	\$ 0.00	\$ 0.00	\$ 0.00	\$ 4,677.00	100.00%	\$ 0.00	\$ 233.85
60	PCCO#004									
60.1	COR#023 Contract Adjustment for Weather Sensitive Work	\$ 0.00	\$ 0.00	\$ 0.00	\$ 0.00	\$ 0.00	\$ 0.00	100.00%	\$ 0.00	\$ 0.00
60.2	COR#025 Delete 2 Pressure Transmitters and Add 2 Differential Pressure Gauges	(\$2,226.60)	\$ 0.00	(\$-2,226.60)	\$ 0.00	\$ 0.00	(\$2,226.60)	100.00%	\$ 0.00	(\$111.33)
60.3	COR#026 Work Change Directive No. 006 - Add Snow Melt System at OH Door Openings	\$ 15,196.77	\$ 0.00	\$ 4,559.03	\$ 0.00	\$ 0.00	\$ 4,559.03	30.00%	\$ 10,637.74	\$ 227.95
60.4	COR#016 Work Change Directive No. 002 - Electrical Changes	\$ 12,167.87	\$ 0.00	\$ 12,167.87	\$ 0.00	\$ 0.00	\$ 12,167.87	100.00%	\$ 0.00	\$ 608.39
60.5	COR#027 RFI-004 - Additional Concrete Around Existing Pump Station	\$ 2,949.57	\$ 0.00	\$ 2,949.57	\$ 0.00	\$ 0.00	\$ 2,949.57	100.00%	\$ 0.00	\$ 147.48
60.6	COR#028 Rotate Carbon Scrubber 180 Degrees	\$ 2,007.15	\$ 0.00	\$ 2,007.15	\$ 0.00	\$ 0.00	\$ 2,007.15	100.00%	\$ 0.00	\$ 100.36
60.7	COR#024 Modify Splitter Box Baffle Wall	\$ 3,317.22	\$ 0.00	\$ 3,317.22	\$ 0.00	\$ 0.00	\$ 3,317.22	100.00%	\$ 0.00	\$ 165.86
TOTALS:		(\$62,920.02)	(\$96,332.00)	\$ 22,774.24	\$ 0.00	\$ 0.00	(\$73,557.76)	116.91%	\$ 10,637.74	\$ 3,457.37

Grand Totals

A ITEM NO.	B DESCRIPTION OF WORK	C SCHEDULED VALUE	D WORK COMPLETED		E THIS PERIOD	F MATERIALS PRESENTLY STORED (NOT IN D OR E)	G TOTAL COMPLETED AND STORED TO DATE (D+E+F)	H % (G / C)	I BALANCE TO FINISH (C - G)	I RETAINAGE
			FROM PREVIOUS APPLICATION (D + E)	THIS PERIOD						
GRAND TOTALS:		\$ 2,425,174.26	\$ 1,959,798.93	\$ 209,830.65	\$ 30,816.00	\$ 2,200,355.58	90.73%	\$ 224,818.68	\$ 64,889.26	

DOCUMENT DETAIL SHEET - APPLICATION AND CERTIFICATE FOR PAYMENT

Date of Issuance: March 13, 2019	Effective Date: April 1, 2019
Owner: City of Ketchum, Idaho Sun Valley Water & Sewer District (SVWSD)	Owner's Contract No.:
Contractor: RSCI, Inc.	Contractor's Project No.:
Engineer: HDR Engineers, Inc.	Engineer's Project No.: 10041918
Project: Headworks Improvements	Contract Name: Ketchum/SVWSD Headworks Improvements

The Contract is modified as follows upon execution of this Change Order:

Description:

1. Work Change Directive (WCD) #002. Electrical changes to account for changes made to the Owner Furnished Equipment washer and other miscellaneous electrical improvements to the scope of work. Add \$12,167.87.
2. Change splitter box bypass wall height. Bypass wall height lowered by saw cutting to better match the hydraulic condition of upstream manholes. Add \$3,317.22.
3. Removal of suction side ODA fan pressure sensors and replacement with manual differential pressure gages. Credit (\$2,226.60).
4. Add snow melt heat trace under overhead doors to avoid damage due to freezing at thresholds. Add \$15,196.77.
5. Add concrete to the east and south sides of the lift station for improved access to ODA equipment. Add \$2,949.57.
6. Change orientation of carbon scrubber for improved access to manway on vessel. Add \$2,007.15.
7. Contract days added for work change items included in Change Order #04 and delays related to Owner furnished equipment repairs and weather sensitive construction: Add 35 days for substantial completion and 77 days for final completion. No change in cost for the days added to completion times agreed to with RSCI.

TOTAL = \$12,167.87 + \$3,317.22 + (\$2,226.60) + \$15,196.77 + \$2,949.57 + \$2,007.15 = \$33,411.98.

Attachments:

- 1. RSCI PCCOR #016 (attached).
- 2. RSCI PCCOR #024 (attached).
- 3. RSCI PCCOR #025 (attached).
- 4. RSCI PCCOR #026 (attached).
- 5. RSCI PCCOR #027 (attached).
- 6. RSCI PCCOR #028 (attached).
- 7. RSCI PCCOR #023 (attached).

CHANGE IN CONTRACT PRICE	CHANGE IN CONTRACT TIMES <i>[note changes in Milestones if applicable]</i>
Original Contract Price:	Original Contract Times: May 21, 2018 (NTP)
\$ 2,481,360.00	Substantial Completion: <u>270</u> days
	Ready for Final Payment: <u>300</u> days
	days or dates
<u>[(Increase) (Decrease)]</u> from previously approved Change Orders No. <u>01</u> , No. <u>02</u> and No. <u>03</u> :	<u>[(Increase) (Decrease)]</u> from previously approved Change Orders No. <u>01</u> , No. <u>02</u> and No. <u>03</u> :
\$ <u>89,597.72</u>	Substantial Completion: <u>28</u>
	Ready for Final Payment: <u>28</u>

EJCDC

Contract Price prior to this Change Order: \$ <u>2,391,762.28</u>	Contract Times prior to this Change Order: Substantial Completion: <u>298 (March 15, 2019)</u> Ready for Final Payment: <u>328 (April 14, 2019)</u> days (dates)
[Increase] [Decrease] with Change Order: \$ <u>33,411.98</u>	[(Increase) (Decrease)] of this Change Order: Substantial Completion: <u>35</u> Ready for Final Payment: <u>77</u> days (dates)
Contract Price incorporating this Change Order: \$ <u>2,425,174.26</u>	Contract Times with all approved Change Orders: Substantial Completion: <u>333 (April 19, 2019)</u> Ready for Final Payment: <u>405 (June 30, 2019)</u> days (dates)

RECOMMENDED: HDR Engineering, Inc.

By: *Paedy*
Engineer

Title: Sr. Project Engineer

Date: March 15, 2019

ACCEPTED: RSCI

By: *[Signature]*
Contractor (Authorized Signature)

Title: President

Date: 3/26/19

ACCEPTED: City of Ketchum, Idaho

By: *[Signature]*
Owner (Authorized Signature)

Title: Mayor

Date: 3/18/19

ACCEPTED: Sun Valley Water & Sewer District

By: *[Signature]*
Owner (Authorized Signature)

Title: WALB / 3/18/19

Date: 3/18/19

"Remit To"

ENVIRO-CARE COMPANY
1570 ST. PAUL AVE.
GURNEE, IL 60031
USA

67-4350-7B10
Contract# 20150
All k4
43504

INVOICE

Invoice Number: WEC215220-O&M
Invoice Date: Nov 26, 2018
Page: 1

Voice: 815.636.8306
Fax: 815.636.8302

Duplicate

Ketchum, ID/Sun Valley WSD
KECTHUM CITY HALL
PO BOX 2315
KETCHUM, ID 83340
USA

Ketchum/Sun Valley WWTP
KETCHUM/SVSWD WWTP
110A RIVER RANCH ROAD
KETCHUM, ID 83340
USA

KETCHUM	10041918	SEE PAYMENT TERMS BELOW
COOMBS	Best Way	3/31/19

Qty	Description	Unit Price	Amount	Balance
1.00	CITY OF KETCHUM AND SUN VALLEY, ID			
1.00	Headworks Improvements - Screen and Washer/Compactor Procurement			
1.00	FSM Perforated Filter Screen Model FRSIII and FSM Screenings Wash Press Model SPW			
1.00	Total PO Cost: \$ 202,000.00			
1.00	"A" Unit FSM- Model FRSIII 800			
1.00	5% Due net30 days after delivery of Final O&M Manuals		7,500.00	7,500.00
1.00	5% Due net30 dyas after delivery of Final O&M Manuals		2,600.00	2,600.00
	PLEASE NOTE: DUE DATE FOR O&M INVOICE WILL BE ADJUSTED PROPERLY AFTER DELIVERY OF FINAL O&M MANUALS			

Subtotal	10,100.00
Sales Tax	
Freight	
Total Invoice Amount	10,100.00
Payment/Credit Applied	

Check/Credit Memo No:

A 1.5% Monthly Late Fee will apply to pmts rec'd more than 30 days after shipm.

"Remit To"

ENVIRO-CARE COMPANY

1570 ST. PAUL AVE.
GURNEE, IL 60031
USA

67-4350-7810
Contract # 20150
ML Mix
435004

INVOICE

Invoice Number: WEC215220-STARTUP
Invoice Date: Nov 26, 2018
Page: 1

Duplicate

Voice: 815.636.8306
Fax: 815.636.8302

Bill To:
Ketchum, ID/Sun Valley WSD
KECTHUM CITY HALL
PO BOX 2315
KETCHUM, ID 83340
USA

Ship To:
Ketchum/Sun Valley WWTP
KETCHUM/SVSWD WWTP
110A RIVER RANCH ROAD
KETCHUM, ID 83340
USA

City	Zip	Payment Terms
KETCHUM	10041918	SEE PAYMENT TERMS BELOW
Company	Shipping	Date
COOMBS	Best Way	3/16/19
		4/15/19

Qty	Item	Unit Price	Amount
1.00	CITY OF KETCHUM AND SUN VALLEY, ID		
1.00	Headworks Improvements - Screen and Washer/Compactor Procurement		
1.00	FSM Perforated Filter Screen Model FRSIII and FSM Screenings Wash Press Model SPW		
1.00	Total PO Cost: \$ 202,000.00		
1.00	"A" Unit FSM- Model FRSIII 800	7,500.00	7,500.00
1.00	5% Due net30 days after Startup and Training and training. Not to exceed 120 days from equipment delivery.		
1.00	"B" Unit FSM-Model SPW 200	2,600.00	2,600.00
1.00	5% Due net30 days after Startup and Training and training. Not to exceed 120 days from equipment delivery.		
	PLEASE NOTE: DUE DATE FOR STARTUP INVOICE WILL BE ADJUSTED PROPERLY AFTER COMPLETION OF STARTUP		

Subtotal	10,100.00
Sales Tax	
Freight	
Total Invoice Amount	10,100.00
Payment/Credit Applied	
TOTAL	10,100.00

Check/Credit Memo No:

A 1.5% Monthly Late Fee will apply to prmts rec'd more than 30 days after shipm.

CH2MHILL Engineering Support Services Summary

March 30, 2019 through April 26, 2019

TO: Patrick McMahon, General Manager
FROM: John Wiskus, P.E.
DATE: May 15, 2019
PROJECT NUMBER: 154047.A0.60

The following is a summary of our activities for the period noted above.

Admin and General Consulting

Activities include project management and administration; communication/coordination with staff and District Staff; review and finalization of the summary of current proven Beneficial Use Water Rights held by the District for the draft Proof of Beneficial Use (POBU) submittal package for the Idaho Department of Water Resources (IDWR); review and update of District's ECUs added since 2005 to establish basis for POBU for Well 13 for the draft POBU submittal package for IDWR; preparation of site photos for the draft POBU submittal Package for IDWR; crosscheck of the District's application for POBU package for Well 12 with the draft POBU application for Well 13; review of J. Stanton/IDWR review comments related to the water rights application submitted by the District in 2005 to establish basis and need for Well 13; preparation of the draft Statement of Completion for submittal with the draft POBU submittal package for IDWR; preparation of the draft Beneficial Use Field Report for inclusion with the draft POBU submittal package for IDWR; assembly of the draft POBU submittal package for review with IDWR; preliminary meeting with Dan Nelson/IDWR, including Pat McMahon, Evan Robertson, Kevin Boggs, and John Wiskus to walk through and review the District's draft POBU submittal package for Well 13; post IDWR review meeting debrief with Pat, Evan, Kevin, and John to identify action items and revisions to the final POBU submittal package for IDWR; preparation of historical well pumping rate and reservoir level/drafting rate documentation for the July 20, 2003 Peak Hour Demand event that will be used to establish the basis for the POBU for Well 13 and future Well 14; preparation of the final narrative explaining the basis for the Peak Hour Demand value of 3.32 gpm/ECU that will be used to establish the POBU for Well 13; incorporation of final revisions and edits requested by IDWR into the final POBU submittal package for IDWR; preparation and assembly of the final POBU wet signature submittal package and transmittal for delivery to IDWR.



154047CH008
Boise, ID 83702
Phone No. 208 345-5310
FAX No. 208 345-5315

Remit To: CH2M Inc.
P.O. BOX 200991
Dallas, TX 75320-0991

Sun Valley Water & Sewer District
Attention: Pat McMahon, General Manager
P.O. Box 2410
Sun Valley ID 83353

Date: 15-May-19
Project No.: 154047
Client Ref. No.: 865
Invoice No.: 154047CH008

INVOICE

For services from March 30, 2019 through April 26, 2019, for Sun Valley Water & Sewer District Engineering Services.

Professional Services:

Class/Grade	Employee Name	Hours	Rate	Amount
TC43100	Boggs, Kevin	5.0	\$189.75	\$948.75
PD53300	Wiskus, John E	81.0	\$205.42	\$16,639.02
		86.0		\$17,587.77

Expenses:

Computers	\$494.50
	<u>\$494.50</u>

AMOUNT DUE FOR CURRENT BILLING

\$18,082.27

DUE AND PAYABLE ON RECEIPT OF INVOICE. FINANCE CHARGES WILL BE ASSESSED AT 1 1/2 PERCENT PER MONTH (OR MAXIMUM PERMISSIBLE UNDER STATE LAW) ON ALL ACCOUNTS OVERDUE UNLESS STATED OTHERWISE IN OUR CONTRACT. CH2MHILL IS INCORPORATED.

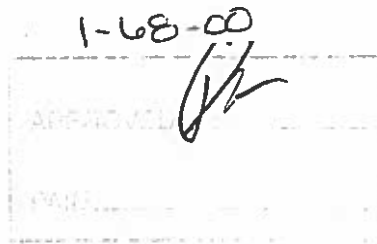

Sun Valley Water & Sewer District

Invoice #: 154047CH008

**PM: John Wiskus
Project # 154047
5/15/2019**

Project Description	Labor	Expense	Total
Admin and General Consulting	\$17,587.77	\$494.50	\$18,082.27
Total	\$17,587.77	\$494.50	\$18,082.27

CH2MHILL Engineering Support Services Summary

February 23, 2019 through March 29, 2019

TO: Patrick McMahon, General Manager

FROM: John Wiskus, P.E.

DATE: April 29, 2019

PROJECT NUMBER: 154047.A0.60

The following is a summary of our activities for the period noted above.

Admin and General Consulting

Activities include project management and administration; communication/coordination with staff and District Staff; review of the systemwide EC's summary spreadsheets prepared by the District to differentiate actual EC's currently serving customers versus pipe in the ground to serve future EC's; revision and update of the systemwide EC's summary spreadsheets prepared by the District in preparation of a meeting with District Staff to finalize the District's EC's added since 2005; site visit and meeting with District Staff to review the updated summary of beneficial use water rights, systemwide EC's added from 2005 to 2018, and to identify missing EC information and data; and updates to the District's EC's added since 2005 in anticipation of an upcoming pre-submittal beneficial use meeting with Dan Nelson/IDWR to review our approach and documentation for Proof of Beneficial Use for Well No. 13.



154047CH007
Boise, ID 83702
Phone No. 208 345-5310
FAX No. 208 345-5315

Remit To: CH2M Inc.
P.O. BOX 200991
Dallas, TX 75320-0991

Sun Valley Water & Sewer District
Attention: Pat McMahon, General Manager
P.O. Box 2410
Sun Valley ID 83353

Date: 9-Apr-19
Project No.: 154047
Client Ref. No.: 865
Invoice No.: 154047CH007

INVOICE

For services from February 23, 2019 through March 29, 2019, for Sun Valley Water & Sewer District Engineering Services.

Professional Services:

Class/Grade	Employee Name	Hours	Rate	Amount
PD53300	Wiskus, John E	30.0	\$205.42	\$6,162.60
		30.0		\$6,162.60

Expenses:

Computers	\$172.50
	<u>\$172.50</u>

AMOUNT DUE FOR CURRENT BILLING

\$6,335.10

DUE AND PAYABLE ON RECEIPT OF INVOICE. FINANCE CHARGES WILL BE ASSESSED AT 1 1/2 PERCENT PER MONTH (OR MAXIMUM PERMISSIBLE UNDER STATE LAW) ON ALL ACCOUNTS OVERDUE UNLESS STATED OTHERWISE IN OUR CONTRACT. CH2MHILL IS INCORPORATED

A-03-63

K

Sun Valley Water & Sewer District

Invoice #: 154047CH007

**PM: John Wiskus
Project # 154047
4/9/2019**

Project Description	Labor	Expense	Total
Admin and General Consulting	\$6,162.60	\$172.50	\$6,335.10
Total	\$6,162.60	\$172.50	\$6,335.10

Mahlke Hunsaker & Company, PLLC

201 Canyon Crest Drive, Ste 100

Twin Falls, ID 83301

Sun Valley Water & Sewer District

PO Box 2410

Sun Valley, ID 83353

5/1/2019

Inv. #: 1-2245

For Professional services rendered:

Professional Fees:

Dale Bunn request for workpapers and prior year entries \$ 630.00

Subtotal: \$ 630.00

Total: \$ 630.00

All Invoices due on presentation

4-03-12
M



Integrity Inspection Solutions, Inc

204 S Dudley Ln
Nampa, ID 83687

Phone (208) 442-4470
Fax (844) 351-6902

Invoice

Date	Invoice #
5/3/2019	FY19M5-24

Account #
19-0117

Bill To

Sun Valley Water & Sewer District
Attn: Chris Benson
PO Box 2410
Sun Valley, ID 83353

Payment Terms	Project
*Net 30	Manhole Infiltration Project

Service Date	Description	Quantity	Unit Price	Amount
5/2/2019	Manhole @ Snowcup Ln	1	750.00	750.00
	Manhole @ Village Way & round-about	1	650.00	650.00
	Manhole @ Angani Way & Senabi Ln	1	650.00	650.00
	Manhole @ Sun Peak Dr. & Easement	1	850.00	850.00
	Manhole 2 @ Sun Peak Dr. & Easement	1	750.00	750.00
	Mob	1	800.00	800.00
<i>4-03-64</i> <i>R</i>				
Total				\$4,450.00

Thank you for your business!

*1.50% finance charge on balances over 30 days



STATE INSURANCE FUND

1215 W. STATE STREET
BOISE, IDAHO 83720-0044
(208) 332-2100 / 1-800-334-2370

10027275000484010201000000

Amount Due: \$7,444.00
Payment Due Date: 06/01/2019
Statement Date: 05/07/2019

Page 1 of 2

POLICY STATEMENT

Sun Valley Water & Sewer District
PO Box 2410
Sun Valley, ID 83353-2410

AGENT: 317
Sun Valley Insurance Inc
PO Box 5808
Ketchum, ID 83340-5808

Policy Number: 411380
Policy Effective Date: 04/01/2019
Statement Number: 20716398

Summary of Activity

Beginning Balance	+ Charges	- Payments/Credits	= Current Statement Balance
\$0.00	\$7,444.00	\$0.00	\$7,444.00

Financial Transactions

Policy / Reporting Period	Transaction Date	Description	Charges/Credits
04/01/2019 - 04/01/2020	04/01/2019	Installment premium	\$6,608.00
04/01/2018 - 04/01/2019	05/06/2019	Audit premium adjustment	\$836.00

4-01-24
Y

To Ensure Proper Credit, Detach Here and Return Bottom Section with Payment - Include Policy Number on Check

Sun Valley Water & Sewer District
PO Box 2410
Sun Valley, ID 83353-2410

Policy #: 411380
Statement #: 20716398
Amount Due: \$7,444.00
Payment Due Date: 06/01/2019

Amount Enclosed

\$ _____

"X" Box if Address Change

New Address: _____

New Phone #: _____

Remit payment to:

STATE INSURANCE FUND
PO BOX 990002
BOISE, IDAHO 83799-0002

Visit our Website at www.idahosif.org.
Pay on-line/review billing/policy details.
Find out if Online Payroll Reporting is for you.

701

000411380

020716398

000744400



Statement Number: 20716398
 Statement Date: 05/07/2019

Page 2 of 2

Audit Premium Adjustment Detail

Class	Description	Payroll	Rate	Prem Charge
Reporting Period: 04/01/2018 to 04/01/2019				
INSURED: Sun Valley Water & Sewer District				
Sun Valley Water & Sewer District 49 Larrys Ln Sun Valley				
7520-000	WATERWORKS OPERATION & DRIVERS	\$223,107	\$3.29	\$7,340.00
8742-001	ADMIN DUTIES - OFFICE & TRAVEL	\$167,913	\$0.43	\$722.00
8811-001	BOARD & COMMISSION MEMBERS	\$10,000	\$0.18	\$18.00
9402-003	SEWER/SEPTIC TANK CLEANING & DRIVERS	\$7,936	\$4.64	\$368.00
	Experience Modification Premium		0.88	(\$1,014.00)
	Total Standard Premium			\$7,434.00
	Total Amount Reported			\$7,434.00
	Less: Prior Billed Premium			\$6,598.00
	Audit Premium Adjustment			\$836.00

Banyan Technologies Inc.

Invoice

P.O. Box 5083
Twin Falls, Idaho 83303-5083

Date	Invoice #
4/30/2019	20573

Bill To
Sun Valley Water & Sewer District P.O. Box 2410 Sun Valley, Idaho 83353

Ship To

P.O. Number	Terms	Rep	Ship	Via	F.O.B.	Project
	Net 30		4/30/2019			

Quantity	Item Code	Description	Price Each	Amount
12	Consulting	Web Site Modifications, Adobe Install - Bronson (No Charge)	0.00	0.00
1	Software	Acrobat Pro Serial Number - ADB00APW74888360604	559.00	559.00
1	Service Ag	Service Agreement 04/01/19 - 04/01/20	6,940.00	6,940.00
6	Consulting	Re-use Lift Station Startup - Tune Drives 04/25/19	105.00	630.00
172	Travel	Travel 04/25.19	0.555	95.46
		Idaho Sales Tax	6.00%	0.00

4-02-31 559.00 LifeSupp
 4-03-70 725.46 - Reuse R/M
 4-03-63- 6940.00 - Water R/M
 R

Total			\$8,224.46
--------------	--	--	------------



PACIFIC

STEEL & RECYCLING™

P O BOX 1413 1987 Highland Ave E Twin Falls, ID 83303-1413 (208 734-7440)

PURCHASE TICKET		3558401
PURCHASE DATE	04/16/19	
PURCHASE TYPE	CASH / CHECK	
CHECK NUMBER	119228	
CHECK AMOUNT	\$587.00	
CASH AMOUNT	\$0.00	
Reese D		23

PURCHASED FROM	1193751
PATRICK JOSEPH MCMAHON 206 SUNRISE DR SUN VALLEY, ID 83353	

--

QUANTITY		Description	PRICING		Amount
Purchased	UOM		UOM	Per Unit	
97	LB	Copper	LB	2.0000	194.00
25	LB	Ins Cu	LB	1.6000	40.00
250	LB	Yellow Brass	LB	1.2500	312.50
25	LB	Yellow Brass	LB	0.5000	12.50
700	LB	Scrap Iron	LB	0.0400	28.00
TOTAL QUANTITY					1,097
TOTAL AMOUNT					\$587.00

TRANSACTION DATE AND TIME: 04/16/19 2:28 PM

I, the undersigned, affirm under the penalty of law that the property that is subject to this transaction is not to the best of my knowledge stolen property.

SELLER SIGNATURE

WITNESS SIGNATURE



CPAs & BUSINESS ADVISORS

INVOICE

Sun Valley Water & Sewer District
PO Box 2410
Sun Valley ID83353

Invoice #: EI00817496
Client #: 198318
Invoice Total: \$11,337.00

Please return top portion with payment

Invoice Is Due Upon Receipt

Progress billing for 2018 annual audit	10,000.00
Expenses at actual	1,337.00
Invoice Total	<u>\$ 11,337.00</u>

4-03-42

APPROVED

PAID _____

Date: 04/24/19 Invoice #: EI00817496 Sun Valley Water & Sewer District

Page: 1

Pay by Mail:
Eide Bailly LLP
877 W. Main St., Ste. 800
Boise, ID 83702-5858
Phone 208.344.7150 | Fax 208.344.7435

Pay Online: www.eidebailly.com/PayBill
Pay by ACH:
ACH Routing # 091310521
Bell Bank Checking Acct # 650200538
Acct Name: Eide Bailly LLP-Boise Office

Monthly 1.0% Late Fee Accrued on Balances Over 30 Days Past Due

Request for Taxpayer Identification Number and Certification

Give Form to the
 requester. Do not
 send to the IRS.

▶ Go to www.irs.gov/FormW9 for instructions and the latest information.

1 Name (as shown on your income tax return). Name is required on this line; do not leave this line blank.
Eide Bailly LLP

2 Business name/disregarded entity name, if different from above

3 Check appropriate box for federal tax classification of the person whose name is entered on line 1. Check only one of the following seven boxes.

Individual/sole proprietor or single-member LLC C Corporation S Corporation Partnership Trust/estate

Limited liability company. Enter the tax classification (C=C corporation, S=S corporation, P=Partnership) ▶ P

Note: Check the appropriate box in the line above for the tax classification of the single-member owner. Do not check LLC if the LLC is classified as a single-member LLC that is disregarded from the owner unless the owner of the LLC is another LLC that is not disregarded from the owner for U.S. federal tax purposes. Otherwise, a single-member LLC that is disregarded from the owner should check the appropriate box for the tax classification of its owner.

Other (see instructions) ▶

4 Exemptions (codes apply only to certain entities, not individuals; see instructions on page 3):

Exempt payee code (if any) _____

Exemption from FATCA reporting code (if any) _____

(Applies to accounts maintained outside the U.S.)

5 Address (number, street, and apt. or suite no.) See instructions.
PO Box 2545

6 City, state, and ZIP code
Fargo, ND 58108-2545

7 List account number(s) here (optional)

Requester's name and address (optional)

Print or type.
See Specific Instructions on page 3.

Part I Taxpayer Identification Number (TIN)

Enter your TIN in the appropriate box. The TIN provided must match the name given on line 1 to avoid backup withholding. For individuals, this is generally your social security number (SSN). However, for a resident alien, sole proprietor, or disregarded entity, see the instructions for Part I, later. For other entities, it is your employer identification number (EIN). If you do not have a number, see *How to get a TIN*, later.

Social security number

			-			-			
--	--	--	---	--	--	---	--	--	--

OR

Employer identification number

4	5	-	0	2	5	0	9	5	8
---	---	---	---	---	---	---	---	---	---

Note: If the account is in more than one name, see the instructions for line 1. Also see *What Name and Number To Give the Requester* for guidelines on whose number to enter.

Part II Certification

Under penalties of perjury, I certify that:

- The number shown on this form is my correct taxpayer identification number (or I am waiting for a number to be issued to me); and
- I am not subject to backup withholding because: (a) I am exempt from backup withholding, or (b) I have not been notified by the Internal Revenue Service (IRS) that I am subject to backup withholding as a result of a failure to report all interest or dividends, or (c) the IRS has notified me that I am no longer subject to backup withholding; and
- I am a U.S. citizen or other U.S. person (defined below); and
- The FATCA code(s) entered on this form (if any) indicating that I am exempt from FATCA reporting is correct.

Certification instructions. You must cross out item 2 above if you have been notified by the IRS that you are currently subject to backup withholding because you have failed to report all interest and dividends on your tax return. For real estate transactions, item 2 does not apply. For mortgage interest paid, acquisition or abandonment of secured property, cancellation of debt, contributions to an individual retirement arrangement (IRA), and generally, payments other than interest and dividends, you are not required to sign the certification, but you must provide your correct TIN. See the instructions for Part II, later.

Sign Here Signature of U.S. person ▶ Jamie Buerkle Date ▶ 1/02/2019

General Instructions

Section references are to the Internal Revenue Code unless otherwise noted.

Future developments. For the latest information about developments related to Form W-9 and its instructions, such as legislation enacted after they were published, go to www.irs.gov/FormW9.

Purpose of Form

An individual or entity (Form W-9 requester) who is required to file an information return with the IRS must obtain your correct taxpayer identification number (TIN) which may be your social security number (SSN), individual taxpayer identification number (ITIN), adoption taxpayer identification number (ATIN), or employer identification number (EIN), to report on an information return the amount paid to you, or other amount reportable on an information return. Examples of information returns include, but are not limited to, the following.

- Form 1099-DIV (dividends, including those from stocks or mutual funds)
- Form 1099-MISC (various types of income, prizes, awards, or gross proceeds)
- Form 1099-B (stock or mutual fund sales and certain other transactions by brokers)
- Form 1099-S (proceeds from real estate transactions)
- Form 1099-K (merchant card and third party network transactions)
- Form 1098 (home mortgage interest), 1098-E (student loan interest), 1098-T (tuition)
- Form 1099-C (canceled debt)
- Form 1099-A (acquisition or abandonment of secured property)

Use Form W-9 only if you are a U.S. person (including a resident alien), to provide your correct TIN.

If you do not return Form W-9 to the requester with a TIN, you might be subject to backup withholding. See What is backup withholding, later.

jeanene@svwsd.com

From: Pat <pat@svwsd.com>
Sent: Friday, May 03, 2019 3:51 PM
To: <jeanene@svwsd.com>; Melissa McKenzie
Subject: Fwd: renewal premium

Begin forwarded message:

From: Betty Urbany <burb@bisnett.com>
Subject: renewal premium
Date: May 3, 2019 at 2:30:06 PM MDT
To: "pat@svwsd.com" <pat@svwsd.com>

Pat,

They have just sent what the renewal premium will be which is \$40,488

Betty Urbany
Bisnett Insurance
Box 5567
Ketchum Id, 83340
burb@bisnett.com
208-726-8866 ext 2



000

770
A

40,488.00+
2,649.00-
2,649.00*+
40,488.00=k
0.07*+
40,488.*



City of Ketchum Utilities Department

P.O. Box 2315
110 River Ranch Road
Ketchum, ID 83340-2315
(208)726-7825
utilities@ketchumidaho.org

Mick Mummert
Wastewater Department Supervisor

April 25, 2019

Tobby Kennedy
Idaho Dept. of Environmental Quality — Twin Falls Region
650 Addison Ave W, Ste 110
Twin Falls, ID 83301

Re: City of Ketchum/Sun Valley Water and Sewer District NPDES Permit ID0020281
Non-Compliance Notification

This is a non-compliance report for an event that occurred on April 22, 2019. This event was reported to the 24hr hotline on April 22, 2019.

The City of Ketchum/Sun Valley Water and Sewer District Wastewater Treatment Plant experienced a biosolids overflow which resulted in approximately 50 gallons of digested sludge being introduced into the Big Wood River.

The overflow was caused by an operator attempting to load a biosolids hauling truck which had been loaded the previous workday. Overflowing sludge ran into a parking lot storm drain which daylighted on the river bank about ten feet from the river. I estimate the sludge was trickling into the drain and to the river bank for approximately 15 minutes. Immediately upon discovering the flow going into the drain, an earthen dam was constructed around the drain to prevent any more flow from getting into it. Also, a plug was inserted into the drain pipe at the riverbank to prevent the sludge in the pipe from escaping. After flow was stopped, the spilled sludge was vacuumed from the parking lot surface and the drain pipe. The entire area, including the pipe, was hosed down and vacuumed again. The sludge that remained on the surface of the river bank was shoveled up after which the rocks and ground were rinsed.

To prevent this from occurring again, we have and will be implementing several corrective actions. First, we have discontinued loading the truck and leaving it loaded overnight. This will ensure one

employee does not load the truck one day and another employee attempting to load an already full truck the next day. Second, I have instructed all operators to visually check to make sure the truck is empty before starting to load it. Another measure we will implement, as soon as possible, to help prevent the truck from overflowing for this and any other reason will be to install a moisture sensor on the truck loading line where it is inserted into the tank. The sensor will automatically stop the loading pump if the tank becomes too full.

I do not believe any adverse impact on the environment or public health resulted from this non-compliance instance. Please contact me (208-726-7825) if you have any questions.

Sincerely,



Mick Mummert
City of Ketchum
Wastewater Department Supervisor

Cc: Neil Bradshaw, Mayor City of Ketchum
Suzanne Frick, City Administrator
Pat McMahon, General Manager Sun Valley Water & Sewer District

DIRECTOR MEMO 2019 -1

Date: May 17, 2019

To: Board of Directors

From: Pat McMahon, General Manager

RE: Upcoming Costs

The District has several projects planned and in progress which will involve major expense, they include;

1. Resurfacing of Larry's Lane, the access road to District Headquarters.
The cost to the District will not exceed \$30,000.00 to cover our third of the total \$77,660.00. Idaho Power and Sun Valley Company are also paying one-third. This work is in progress, the base layer should be completed this week, and the asphalt will be installed as soon as it quits raining.
2. Drilling and development of a test well for Well #14.
Once our water right portfolio is in order, we can apply for a drilling permit for Well #14. The test well would involve drilling a 6" casing to bedrock (approximately 150') and developing the well to identify yield in both quantity and quality for viability as a municipal well. The cost is estimated to be in the \$20,000.00 range. Other expenses which could be incurred in fiscal 2019 include undergrounding of power lines in the area of the wellsite (\$30,000.00) and preliminary engineering work (\$20,000.00).
3. Well #3 Upgrade
This well, put into service in 1948, delivers 400 g.p.m. and is used to meet peak summertime demands. The control valve (ClaValve) is old and does not come on and offline smoothly, resulting in water hammer on start up and shut down. The meter is an obsolete insertion type with questionable accuracy and does not meet current State requirements, it is currently grandfathered in. Although not specifically referred to, this project cost was included in the Capital Improvements line item.
Anticipated costs include:

• Replacement ClaValve	\$8,700.00
• State approved meter	4,135.00
• Vault for meter (installed)	4,000.00
• <u>Piping and fittings</u>	<u>2,000.00</u>
TOTAL	\$18,835.00
4. Dan Springer Retirement
Should the Board decide to fund Dan's vacation balance the cost would be \$35,168.44. Funding of payment at minimum wage for accrued sick would be \$7,530.13, if the Board desired. Potential total cost \$42,698.57.

Ramsay Solutions Inc.

Contractor License RCE-27424
1007G Warm Springs Road
PO Box 4125
Ketchum, Idaho 83340



Sun Valley Water and Sewer District
c/o Pat McMahon
P.O. Box 2410
Sun Valley, Idaho 83353

Project #: 1866-3 (Yuras Residence)
Project Address: 1 Wildrose Lane
Sun Valley, Idaho 83353

Pat,

I hope all is well. On behalf of Michael and Cara Yuras (Client), Ramsay Solutions Inc. (RSInc) is requesting a two (2") inch water service from the Sun Valley Water and Sewer District (SVW&SD) main to accommodate for City of Sun Valley Adopted Code requiring sprinkling the residence.

MAIN SERVICE WATER:

Existing Conditions: SVW&SD has requested the current one (1") inch line be capped at the existing junction. The existing junction is under the driveway of 20 West Lane Ranch Road (Lee's Residence). Capping this junction would entail extensive demolition and subsequent repair of the brand new (Lee's Residence) driveway.

Proposal: If the Client is afforded the opportunity to install a new two (2") inch line tap just North of the Lee's Residence, RSInc and the Client are proposing a Notarized letter signed by the Client holding the Client liable for repair if the existing one (1") line junction is to ever fail in the future.

Summary: Installation of a new two (2") tap North of the Lee's Residence will reduce construction impact to the Lee's Residence and compounding costs for the Client as there was nothing of record forecasting this potential cost. Additionally, if the Client were to utilize the existing one (1") line and the junction were fail, that repair cost would be absorbed by the SVW&SD.

LANDSCAPING WATER:

Proposal: RSInc will provide a one (1") inch line servicing all landscaping features.
SVW&SD will be requested to inspect upon completion.

Most Sincerely,

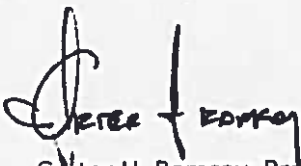
A handwritten signature in black ink, appearing to read "Carter H. Ramsay". The signature is stylized with a large initial "C" and "R".

Carter H. Ramsay, President
Ramsay Solutions, Inc.
2019May16



TRANSMITTAL

To: Idaho Department of Water Resources
322 East Front Street
Suite 600
Boise, ID 83702

From: Kevin Boggs
Jacobs
999 W. Main St. Suite 1200
Boise, ID 83702
208-340-1753

Attn: Dan Nelson

Date: April 30, 2019

Re: Sun Valley Water and Sewer District Water Right 37-21465 Beneficial Use Field Report

We Are Sending You:

Method of shipment:

X Attached

Under separate cover via

Shop Drawings

Documents

Tracings

Prints

Specifications

Catalogs

Copy of letter

Other:

Quantity	Description
1	Sun Valley Water and Sewer District Water Right 37-21465 Beneficial Use Field Report

If the material received is not as listed, please notify me at 208-340-1753.

Copy To: Pat McMahon/General Manager, Sun Valley Water and Sewer District

Evan Robertson\Robertson & Slette, p.l.l.c.

STATE OF IDAHO
DEPARTMENT OF WATER RESOURCES
STATEMENT OF COMPLETION
FOR SUBMITTING PROOF OF BENEFICIAL USE

FOR OFFICE USE ONLY	
Amt. of Fee \$ _____	_____
Receipt No. _____	_____
Received By _____	_____
Date Received _____	_____

The Idaho Department of Water Resources considers this form a statement by the permit holder(s) that development of a water right has been completed and that water has been applied to beneficial use to the extent described below. This form must be accompanied by an examination fee, when necessary, or by a completed Beneficial Use Field Report prepared by a certified water right examiner. Please refer to the instructions and fee schedule for this form. If ownership of the permit has changed, contact any Department office or visit the Department's website at dwr.idaho.gov for an Assignment of Permit form. If you wish to relinquish your permit because you have not established the authorized use of the water and are not applying for an extension, please notify the Department in writing.

1. Permit No. 37-21465 Telephone No. 208-622-9507

2. Name of Permit Holder(s) Sun Valley Water and Sewer District

3. Mailing Address P.O. Box 2410 City Sun Valley

State ID Zip 83353 Email pat@svwsd.com

4. Source of Water Groundwater (well) If GROUND WATER (well), Date Drilled mo. 12 / yr. 06

Well Driller Walker Water Systems Drilling Permit Number 842799

5. Extent of use(s) completed as authorized by the water right permit:

Domestic (No. of households) _____ Stockwater (No. and type of stock) _____

Irrigation (No. of acres) _____ Other Municipal

6. Total rate of diversion or storage volume for which proof is submitted 2.23 cfs OR _____ acre-feet.

7. Compliance with a measuring device requirement, lockable controlling device requirement, and/or other conditions of permit:

Refer to the approval conditions on your permit and respond accordingly.
The Department will not issue a license if permit conditions are not met.

Measuring Device	Is a measuring device required?	Yes <input type="checkbox"/>	No <input checked="" type="checkbox"/>
	If yes, has the measuring device been installed?	Yes <input checked="" type="checkbox"/>	No <input type="checkbox"/>
Lockable Controlling Device	Is a lockable device required to control the diversion?	Yes <input type="checkbox"/>	No <input checked="" type="checkbox"/>
	If yes, has the lockable device been installed?	Yes <input checked="" type="checkbox"/>	No <input type="checkbox"/>
Fish Screen	Is a fish screen required?	Yes <input type="checkbox"/>	No <input checked="" type="checkbox"/>
	If yes, has the fish screen been installed?	Yes <input type="checkbox"/>	No <input checked="" type="checkbox"/>

Other Conditions of Permit

Do the approval conditions on your permit require you to submit additional information in connection with your proof of beneficial use? If yes, list the conditions below and attach documents with the required information.

_____ Completed? Yes No

8. Fee Enclosed \$ NA or not applicable . See fee schedule on page 2 of the instructions.
Proof statements filed without an appropriate fee, will be considered incomplete.

9. Person to contact to accompany the Department representative during field examination of the water system.

Name NA Telephone Number _____

Mailing Address _____ City _____

State _____ Zip _____ Email _____

The information given on this form is my true statement of the extent to which the above numbered permit has been developed and water has been diverted and applied to a beneficial use. I understand that any undeveloped portion of the permit is relinquished to the State of Idaho.

Signature of Permit Holder [Signature] PATRICIA MCGONIGAN OWNER Date 4/30/19
(Include your title, if on behalf of company or organization)

Mail to: Idaho Department of Water Resources, PO Box 83720, Boise, ID 83720-0088

STATE OF IDAHO
DEPARTMENT OF WATER RESOURCES
BENEFICIAL USE FIELD REPORT

A Beneficial Use Field Report is prepared by a water right examiner as the result of an examination to clearly confirm and establish the extent of the beneficial use of water established in connection with a permit during the development period authorized by the permit and any extensions of time previously approved.

A. GENERAL INFORMATION

Permit No. 37-21465

1. Owner Sun Valley Water and Sewer District Phone No. 208-622-9507
Current address P. O. Box 2410
2. Examiner's name Kevin Boggs EXAM DATE 11-1-18
3. Accompanied by Patrick McMahon Email pat@svwsd.com
Address P. O. Box 2410, Sun Valley, ID 83353
Relationship to permit holder SVWSD General Manager Phone No. 208-622-9507
4. Source Groundwater (well) tributary to NA

B. OVERLAP REVIEW

1. Other water rights with the same place of use 37-2709, 37-2722, 37-7102, 37-7147, 37-08834, 37-08835, 37-21151
2. Other water rights with the same source and point of diversion None

C. DIVERSION AND DELIVERY SYSTEM

1. Point(s) of Diversion:

Ident. No.	Gov't Lot	¼	¼	¼	Sec	Twp	Rge	County	Method of Determination/Remarks
Well 13	Unknow	NE	NW	NE	30	04N	18E	Blaine	Records Review and Site Visit

2. Place(s) of Use: Method of determination Records review and site visit - See attached service area map

Twp	Rge	Sec	NE				NW				SW				SE				Totals			
			NE	NW	SW	SE	NE	NW	SW	SE	NE	NW	SW	SE	NE	NW	SW	SE				

3. **Delivery System Diagram:** Indicate all major components and distances between components. Indicate weir size/ditch size/pipe diameter (inside), as applicable. Use the space provided or see attached.

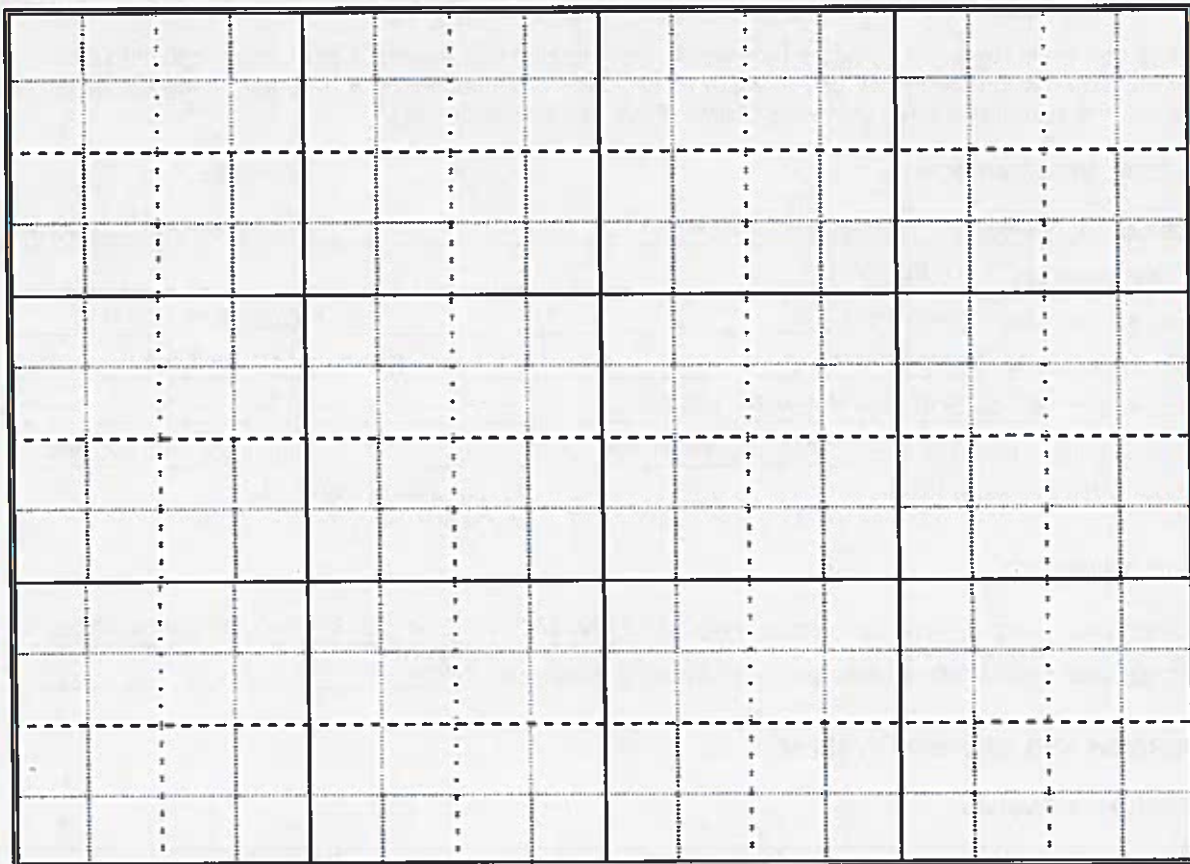

Scale: 1" = _____

- Copy of USGS Quadrangle attached showing location(s) of point(s) of diversion and place(s) of use (required)
- Aerial photo attached (required for irrigation of 10+ acres)
- Photo of diversion and system attached

4.

Well or Diversion Identification No.*	Motor Make	Hp	Motor Serial No.	Pump Make	Pump Serial No. or Discharge Size
Well 13	U.S. Motors	100	Y08-789072-0001-	Goulds	4430337, 8-inch
			GT-01		

*Code to correspond with no. on map and aerial photo

D. FLOW MEASUREMENTS

1.

Measurement Equipment	Type	Make	Model No.	Serial No.	Size	Calib. Date
Totalizer/Flow Meter	Electro-	Sparling	FM-656	M207631617	8-inch	4-25-2017
	magnetic					

2. Measurements: _____

Pumped for 21 minutes at 1,095 gpm, based on totalizer measurements: at 11:47 (87,599,000 gallons); 12:08 (87,622,000 gallons); Pumped 23,000 gallons over 21 minutes = 1,095 gpm (see attached field notes)

E. NARRATIVE/REMARKS/COMMENTS

See attached "Sun Valley/Elkhorn System Beneficial Use Water Rights Review" and attached "SVWSD Single Residential Equivalent Connections and Multi-Family Equivalent Connections Added 2005 through 2018" for future District Water Rights.

Note: the District installed a lockable device to control the diversion. The District also installed an electro-magnetic flow meter.

Note: the multi-family equivalent connections (ECUs) listed in the attached doc ("SVWSD Single Residential Equivalent Connections and Multi-Family Equivalent Connections Added 2005 through 2018") are stubbed-in connections to serve future mobile homes and multi-plexes.

Has the permit holder met all conditions of permit approval, including any mitigation requirements and/or measuring device installation requirements? Yes No If no, what must be done to meet the permit requirements?

F. FLOW CALCULATIONS

Additional computation sheets attached

Measured Method:

Totalizer/Flow Meter; Pumped for 21 minutes at 1,095 gpm, based on totalizer measurements: at 11:47 (87,599,000 gallons); 12:08 (87,622,000 gallons); Pumped 23,000 gallons over 21 minutes = 1,095 gpm (see attached field notes)

G. VOLUME CALCULATIONS

1. Volume Calculations for Irrigation:

$V_{IR} = (\text{Acres Irrigated}) \times (\text{Irrigation Requirement}) = \underline{NA}$

$V_{DR} = [\text{Diversion Rate (cfs)}] \times (\text{Days in Irrigation Season}) \times 1.9835 = \underline{NA}$

$V = \text{Smaller of } V_{IR} \text{ and } V_{DR} = \underline{NA}$

2. Volume Calculations for Other Uses:

NA

H. RECOMMENDATIONS

1. Recommended Amounts

Beneficial Use	Period of Use		Rate of Diversion Q (cfs)	Annual Volume V (afa)
	From	To		
Municipal	01/01	12/31	2.23	NA
_____	_____	_____	_____	_____
_____	_____	_____	_____	_____
_____	_____	_____	_____	_____
Totals:			2.23 cfs	_____

2. Recommended Amendments

- Change P.D. as reflected on page 1
 Add P.D. as reflected on page 1
 None
 Change P.U. as reflected on page 1
 Add P.U. as reflected on page 1
 Other

I. AUTHENTICATION

Field Examiner's Signature

Heidi B...

Date

4/30/2019

Reviewer _____

Date _____



SUN VALLEY WATER AND SEWER DISTRICT WELL 13 BENEFICIAL USE FIELD EXAM ATTACHMENTS:

- FIELD NOTES
- WATER RIGHTS REVIEW AND PEAK USE NARRATIVE
- EQUIVALENT CONNECTION DETAILS
- MAG METER CALIBRATION SHEET
- FIELD PHOTOS
- PUMP AND MOTOR DETAILS
- WELL LOG
- PLACE OF USE MAP
- CITY OF SUN VALLEY WATER CONSERVATION ORDINANCE

Jacobs

Sun Valley Wtr & Sewer District
K. Boggs.

109

11-1-18

Wells - Beneficial Use Exam

11:15 static (system) pressure = 86 psi

11:15 Pump is off; equipped with VFD;
Model = PowerFlex 753; off at 0 Hz
↳ 480V 125A; MAKE = Allen-Bradley

VFD catalog No. = 20F1A N D 125 AN0NNNNN

11:20 Tiger Mag flow meter reading = 8758700 gal
↳ Prior to pumping for this field exam

Note: John Wiskus & Kevin Boggs / Jacobs on site
with Pat MacMahon / SVWSD

MOTOR

US Motor 100HP

Serial No. H0100V2SLG-C (Catalog #)

ID# = Y68-729072-0001-GT-01

PUMP

Goulds

Model No. DWT-FFTM

1000 gpm capacity

Head = 260 TDH

Size = 10 DHHC

8 stages

impeller is 6.13"

Serial No. = 4430337

METER

8" diameter

Sparling

Tiger Mag EP

Model = FM656

Serial No. =

↳ M207031617

Totalizer = Sparling - electro-magnetic; 8-mech

Model No. FM-656

Serial No. M207031617

110

Sun Valley Wtr & Sewer District

11-01-2019

well-13

K. Boyce

11:31 Pump on - pump to waste initially
VFD = 57.199 Hz during pump to waste

11:34 Pump to waste valve closed; pump
to distribution system; discharge
slowly ramped up to approx 1000 gpm
over the course of approx 90 sec

11:36 instan. reading 997 to 1007 gpm
↳ fluctuating; 57.199 Hz

11:38 Totalizer = 87,590,000 gallons; 57.199

11:45 Totalizer = 87,597,000 gallons; 57.199 Hz

11:46 ramp up to 59.999 Hz; instan.
flow meter = 1,145 gpm → fluctuating
by about 10 to 20 gpm.

11:47 totalizer = 87,599,000 gallons; 59.999 Hz
pressure = 98 (almost 99) psi

11:52 Totalizer = 87,605,000 gallons; 59.999 Hz
pressure = 98 (almost 99) psi

11:59 Totalizer = 87,613,000 gallons; 59.999 Hz
pressure = 98 (almost 99) psi

12:08 Totalizer = 87,622,000 gallons; 59.999 Hz
pressure = 98 (almost 99) psi

Totalizer: avg. flow bet 11:47 to 12:08 (21 min)
= 87,622,000 - 87,599,000 = 23,000 gallons

$\frac{23,000 \text{ gal}}{21 \text{ min}} = 1,095 \text{ gallons/min}$

Sun Valley/Elkhorn System Beneficial Use Water Rights Review

Water Right	POD	Water Right Application Rate (cfs)	Water Right Application Rate (gpm)	Approved Beneficial Use Rate (cfs)	Approved Beneficial Use Rate (gpm)
37-2709	Wells 1, 2, and 3	1.78	798.92	1.78	798.92
37-2722	Wells 4A and 5	3.63	1629.26	3.63	1629.26
37-7102	Wells 7, 8, 10, and 11	9.00	4039.49	9.00	4039.49
37-21151	Well 12	3.35	1503.59	2.06	924.60
37-21465	Well 13	2.23	1000.90	2.23	0.00
Totals		19.99	8972.16	18.7	7392.27
Peak Hour Demand, (gpm) 7-20-2003					9235.4 gpm
Peak Hour Demand/ECU, (gpm/ECU) 7-20-2003					3.32 gpm/ECU
ECU 2003 Estimated at 2778					2778 ECU
Peak Hour Demand Shortfall\Excess					-1843.13

The Sun Valley Water and Sewer District water system is supplied by a series of ground water wells that pump into the distribution system and a series of reservoirs located throughout the District. On July 20, 2003 the District experienced a Peak Hour Demand of approximately 9,235 gpm. Based on an equivalent connection unit count of 2,778 this translates into a Peak Hour Demand/ECU of 3.32 gm. At that time the District held approximately 7,392 gpm in water rights with approved beneficial use designation that could be used to meet this Peak Hour Demand. The Peak Hour Demand Shortfall of 1,843 gpm represents the beneficial use water supply shortfall the District experienced on July 20, 2003. This Peak Hour Demand event is based on the sum of the District's well flows for the day and the highest draft rate on the water system reservoirs during that day. The total well pumping recorded on July 20, 2003 was 8,865,900 gallons (6,157 gpm), and the peak reservoir drafting rate totaled approximately 3,078 gpm yielding a peak hour event of 9,235 gpm. Refer to the District's well water production log for the July 20th well flows, and the District's reservoir level graphs for the peak reservoir drafting rates. During this Peak Hour Demand event the District was marginally able to respond to the water demand by drafting and drawdown of the District's reservoirs. As a result, the District applied for a Permit on 9-08-2003 to drill Well No. 12 as a first step to meet the water supply shortfall. The Permit for Well No. 12 was authorized by IDWR on 12-18-2003. Ultimately the Proof of Beneficial Use for Well No. 12 was limited to 2.06 cfs. The District next applied for a Permit on May 20, 2005 to drill Well No. 13. The Permit for Well No. 13 was authorized by IDWR on 7-15-2005. The District also had plans to apply for a Permit to drill Well No. 14. The equivalent connection units (ECUs) detailed on the following two pages represent ECUs served by the District that have come online since 2005, the time of the water right permit application (37-21465). Several other businesses have also come online since 2005.

①

Sun Valley Water & Sewer District

Well Water Production for the month of JULY 20 03 FIELD

Date	WELL #1	WELL #2	WELL #3	WELL #5	WELL #4A
JUN 30	854135 151600	426093 179500	45651 167000	875938 1232000	902427 272700
1	855962 142200	473702 162900	46170 519000	877064 1126000	905415 298800
2	857048 148600	429411 171900	46820 650000	878248 1184000	908268 285300
3	858536 148800	431134 169300	47462 642000	879412 1164000	911131 286300
4	859991 145500	432776 164200	47665 203000	880544 1132000	913935 280400
5	861511 152000	434533 175700	47683 18000	881767 1223000	916999 306400
6	862975 146400	436307 177400	48179 496000	882976 1209000	919796 279700
7	864470 149500	437989 168200	48815 636000	884136 1160000	922938 314200
8	865967 149700	439709 172000	49466 651000	885323 1187000	925972 303400
9	867439 147200	441424 171500	50114 648000	886507 1184000	929150 317800
10	868822 138900	443255 193100	50844 790000	887836 1329000	932069 291900
11	870335 151300	445067 171200	51491 647000	889017 1181000	935428 335900
12	871783 144800	446901 183900	52183 697000	890283 1266000	938988 356000
13	873290 150700	448776 187600	52894 711000	891575 1292000	942396 340800
14	874727 143700	450551 177500	53565 671000	892916 1221000	945612 321600
15	876178 145100	452378 178700	54239 674000	894016 1220000	949284 367200
16	877681 150300	454223 188500	54952 713000	895283 1267000	952518 323400
17	879062 138100	456120 189700	55670 710000	896588 1305000	955722 320400
18	880529 146700	457776 165600	56295 625000	897727 1139000	958864 314200
19	881811 128200	459488 171200	56943 648000	898905 1178000	961862 299800
20	883439 162800	461906 201800	57708 765000	900298 1393000	967291 542900
21	884851 141200	463400 189400	58419 711000	901606 1308000	970936 364500
22	886330 147900	465050 169200	59112 693000	902733 1127000	975766 483000
23	887811 148100	466887 183700	59805 693000	903991 1258000	980638 487200
24	889179 136800	468757 189000	60514 709000	905270 1279000	983870 323200
25	890647 146800	470488 173100	61266 692000	906452 1182000	987511 364100
26	892033 138600	472452 196400	61911 745000	907802 1350100	990835 332400
27	893513 148000	474161 170900	62557 646000	908977 1175000	994210 337500
28	895002 148900	476071 191000	63280 723000	910279 1302000	997022 281200
29	896431 142900	477740 166900	63911 651000	911427 1148000	211 318900
30	897902 147100	479443 170300	64557 646800	912591 1164000	3256 304500
31	899295 139300	481307 186400	65263 706000	913878 1287000	6144 288800
	4516	5521	1961	37940	10372

Sun Valley Water & Sewer District

Well Water Production for the month of: JULY 20 03 FIELD

Date	WELL # 7		WELL # 8		WELL # 11		WELL # 10		-ELKHORN TOTALS	
		00		00		000		00		000
JUN 30	618250	691600	595135	409900	887209	2957000	478820	936700		4995200
1	629184	693400	598108	297300	890010	2801000	488051	923100		4714800
2	632113	692900	601934	382600	892879	2869000	497483	943200		4887900
3	699393	728000	604860	292600	895762	2885000	507094	961100		4864700
4	646442	704900	609251	439000	898386	2624000	518622	1152800		4920700
5	654910	846800	613734	448400	901102	2716000	529960	1133800		5145000
6	661910	700000	617971	423700	903915	2813000	539490	953000		4889700
7	669969	805800	622743	479200	906813	2898000	550328	1083800		5264500
8	676968	660300	630608	786500	909709	2896000	559343	901500		5244300
9	684268	770000	634223	361500	912532	2823000	569669	1032500		4987100
10	691074	680600	638393	417000	915318	2786000	578918	924900		4808500
11	699608	853400	641030	263700	918216	2898000	590390	1147200		5162300
12	708507	889900	645360	433000	920870	2651000	604507	1411700		5388600
13	716940	843300	650907	564700	923756	2886000	615870	1136300		4921300
14	725916	857600	656606	569900	926615	2859000	627908	1183800		5470300
15	734475	899900	662254	564800	929397	2782000	639625	1191700		5434400
16	743031	855600	667370	511600	932330	2933000	652044	1241900		5542100
17	751119	808800	672644	527400	935119	2789000	662820	1077600		5202800
18	759107	798800	677186	454200	937955	2836000	673641	1082100		5171100
19	766927	722000	681642	445600	940738	2483000	683320	967900		4618500
20	775850	952300	688127	648500	943350	2912000	696196	1267600		5800400
21	784751	890100	694233	610600	946254	2904000	708457	1226100		5630800
22	792829	807800	699197	496400	948997	2743000	719445	1098800		5146000
23	801868	903900	704894	569700	951898	2901000	731920	1247500		5622100
24	809410	754200	709287	439300	954590	2692000	742105	1018500		4904000
25	818084	867400	714886	559900	957455	2865000	753909	1180400		5472700
26	825940	785600	719675	478900	959965	2510000	764670	1076100		4850600
27	834032	809200	724516	484100	962488	2523000	775800	1113000		4929300
28	842190	619800	728212	369600	965242	2954000	784087	828700		4568100
29	847574	738400	732882	467000	968137	2895000	793955	988800		5089200
30	859306	773200	737217	433500	970951	2814000	804398	1044300		5265200
31	863373	846700	742691	547400	973644	2693000	815732	1133400		5220500
	24552		14756		86435		33691			

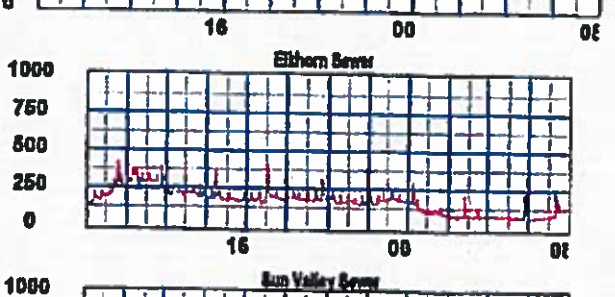
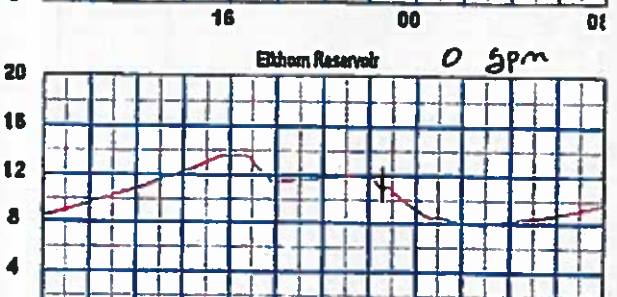
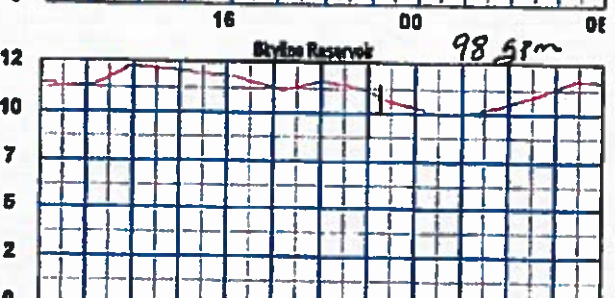
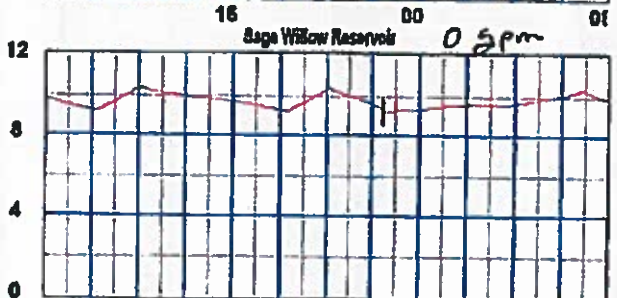
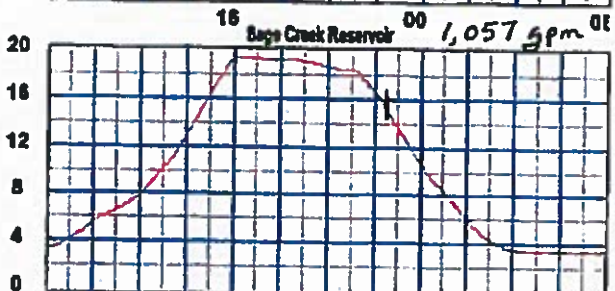
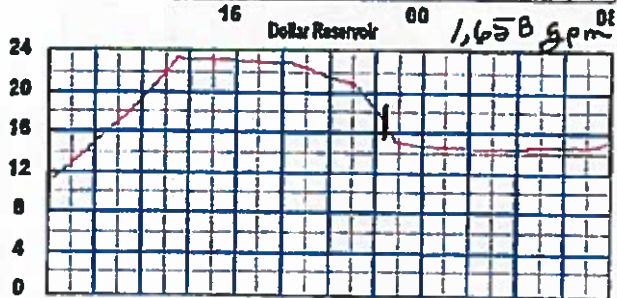
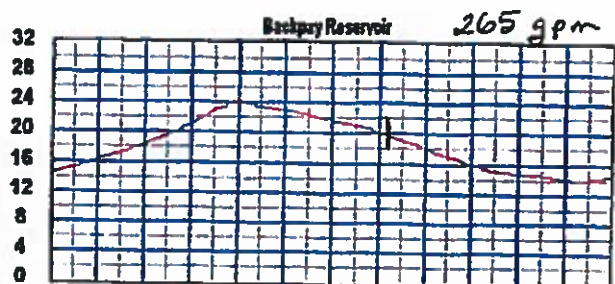
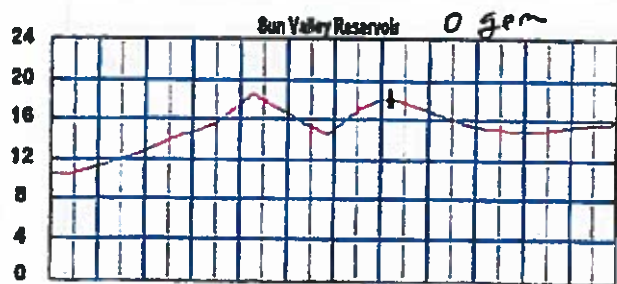

$$\text{PEAK HOUR RESERVOIR DRAWDOWN} = 265 + 1,658 + 1,057 + 98$$

$$= 3,078 \text{ gpm}$$

SVWSD Single Residential Equivalent Connections and Multi-Family Equivalent Connections Added 2005 through 2018				
CUSTOMER#	SERVICE ADDRESS	CONNECTION DATE	SINGLE RESIDENTIAL ECU'S	MULTI FAMILY ECU'S
2004				
1.0029 01	100 FAIRWAY RD	7/1/2005	1	
2.1173 01	DOLLAR MT LODGE WEST	8/31/2005		
3.8197 01	105 SILVER QUEEN	8/1/2005		
4.8201 01	51 LANE RANCH RD	7/1/2005	1	
5.8202 01	89 ELKHORN RD	7/1/2005	1	
6.8203 01	67 LANE RANCH RD	10/1/2005	1	
7.8204 01	85 ELKHORN RD	8/31/2005	1	
8.8209 01	202 CAMAS LOOP	10/1/2005	1	
2006				
9.8206 01	7 MEADOW RD	2/28/2006	1	
10.8207 01	3 LANE RANCH RD	6/1/2006	1	
11.9198 01	115 ANGANI WAY	8/31/2006	1	
12.9198 01	1000102 ANGANI WAY	8/31/2006		2
13.9197 0	95 BADEYANA DRIVE	8/31/2006	1	
14.9198 01	104108 ANGANI WAY	8/31/2006		2
15.9199 01	108 ANGANI WAY	11/30/2006	1	
2007				
16.0018 01	110 SKYLINE RD	8/31/2007	1	
17.1124 01	GOLF COURSE 17TH TEE	11/30/2007		
18.8112 01	59 LANE RANCH RD	8/31/2007	1	
19.8213 01	48 LANE RANCH ROAD	8/31/2007	1	
20.8214 01	227 BLUEBELL	8/31/2007	1	
21.8215 01	120 HIGHLAND DR	8/31/2007	1	
22.9200 01	108 & 110 ANGANI WAY	2/28/2007		2
23.9201 01	101103 SENABI LANE	8/31/2007		2
24.9202 01	105 107 SENABI LANE	8/31/2007		2
25.9203 01	109 111 SENABI LANE	8/31/2007		2
26.9204 01	97 BADEYANA DRIVE	11/30/2007	1	
2008				
27.0030 01	708 FAIRWAY ROAD	2/28/2008	1	
28.0031 01	103 SADDLE LANE	5/30/2008	1	
29.12473 01	228 BITTERROOT ROAD	11/30/2008	1	
30.1174 01	300 DOLLAR ROAD	8/29/2008	1	
31.1175 01	3000 TRAIL CREEK ROAD	8/29/2008	1	
32.1176 01	302 TRAIL CREEK ROAD	11/30/2008	1	
33.8082 01	214 MEADOW CIRCLE	5/1/2008	1	
34.8219 01	210 ELKHORN ROAD	5/30/2008	1	
35.8217 01	108 DEFIANCE	5/30/2008	1	
36.8218 01	25 LANE RANCH ROAD	5/30/2008	1	
37.8219 01	12816 HIGHWAY 75	11/30/2008	1	
38.9205 01	108 VILLAGE WAY BLDG B2	5/30/2008	1	
39.9206 01	TENNIS COURTS LANDSCAPE	7/29/2008		
40.9207 01	102 / 104 SENABI WAY	8/25/2008		2
41.9208 01	104 VILLAGE WAY	8/29/2008	1	
42.9209 01	12812 12814 HIGHWAY 75	11/30/2008		2
43.9210 01	1281812820 HIGHWAY 75	11/30/2008		2
44.9211 01	101-117 BLUE HAVEN DRIVE	11/30/2008		16
45.9212 01	12598 HIGHWAY 75	11/30/2008		2
46.9213 01	12608 HIGHWAY 75	11/30/2008		2
2009				
47.8177 01	300 TRAIL CREEK ROAD	2/28/2009		
2010				
48.21125 01	WHITE CLOUDS RESERVOIR	8/31/2010		
49.8220 01	17 LANE RANCH ROAD	5/31/2010	1	
50.8221 01	209 MEADOWRIDGE	8/31/2010	1	
51.8214 01	SAGEWILLOW EQUINE STRIP PATH	8/18/2010		
52.9215 01	SAGEWILLOW ARROWLEAF	8/18/2010		
53.9216 01	UPPER POND FENCE	11/1/2010		
54.9217 01	12568 HIGHWAY 75	11/29/2010	1	
55.9218 01	12590 HIGHWAY 75	11/30/2010	1	
2011				
2012				
56.10030 01	108 WEDDELN LANE	11/30/2012	1	
57.21178 01	WHITE CLOUD TOWNHOMES	5/31/2012		
58.21179 01	15 CLOUD NINE DRIVE	5/31/2012	1	
59.21180 01	11 CLOUD NINE DRIVE	5/31/2012	1	
60.21181 01	18 & 12 CLOUD NINE DRIVE	5/31/2012		2
61.8173 01	717 MORNINGSTAR	10/1/2012	1	
62.9219 01	102 SENABI LANE	8/29/2012	1	
2013				
63.10037 01	701 FAIRWAY ROAD	11/28/2013	1	
64.10032 01	2 BACK PAY WAY	8/30/2013	1	
65.21182 01	17 CLOUD NINE DRIVE	5/31/2013	1	
66.21183 01	19 CLOUD NINE DRIVE	5/31/2013	1	
67.21184 01	14 & 16 CLOUD NINE DRIVE	5/24/2013		
68.21185 01	100 SUN PEAK DRIVE	8/30/2013	1	
69.21186 01	28 CLOUD NINE DRIVE	11/29/2013	1	
70.21187 01	21 & 23 CLOUD NINE DRIVE	11/29/2013		
71.8075 01	115 SAGEWILLOW RD	5/24/2013	1	
72.9220 01	105 HOSPITAL DRIVE	5/24/2013	1	
73.9221 01	147 HOSPITAL DRIVE	5/24/2013	1	
2014				
74.10038 01	210 SUN PEAK DRIVE	8/28/2014	1	

	A	B	C	D	E
	CUSTOMER#	SERVICE ADDRESS	CONNECTION DATE	SINGLE RESIDENTIAL ECU'S	MULTI FAMILY ECU'S
90	1 0039 01	205 FAIRWAY ROAD	8/25/2014	1	
91	1 0040 01	8 BACK PAV WAY	11/30/2014	1	
92	1 6083 01	1 LANE CREEK ROAD	5/27/2014	1	
93		2018			
94	1 0041 01	107 FAIRWAY ROAD	5/31/2015	1	
95	1 0042 01	423 FAIRWAY LOOP	11/17/2015	1	
96	2 1189 01	101 107 ELLE ROAD	2/28/2015		2
97					
98	2 1189 01	142 & 144 CLOS DU VAL	5/31/2015		2
99	2 1190 01	140 & 148 CLOS DU VAL	5/31/2015		2
100	2 1191 01	110 & 112 ELLE ROAD	5/31/2015		2
101	2 1192 01	112 ELLE ROAD	8/25/2015	1	
102	2 1193 01	138 & 140 CLOS DU VAL	11/30/2015		2
103	2 1194 01	136 CLOS DU VAL	11/30/2015	1	
104	1 6094 01	712 MORNINGSTAR	5/31/2015	1	
105	1 8222 01	170 LANE'S WAY	11/30/2015	1	
106	1 8223 01	190 LANE'S WAY	11/30/2015	1	
107		2019			
108	1 0043 01	315 DIAMOND BACK ROAD	2/28/2016	1	
109	2 1195 01	102 108 ELLE ROAD	5/25/2016		2
110	1 9222 01	113 115 SENABI LANE	2/26/2016		2
111		2017			
112	1 0044 01	305 DIAMOND BACK ROAD	5/31/2017	1	
113	2 1196 01	132 & 134 CLOS DU VAL	5/31/2017		2
114	2 1197 01	122 CLOS DU VAL	5/31/2017	1	
115	2 1198 01	120 CLOS DU VAL	5/31/2017	1	
116	2 1199 01	201 DIAMOND BACK-JOB TRAILER	5/31/2017	1	
117	1 8224 01	160 LANE'S WAY	5/31/2017	1	
118	1 8225 01	129 LANE'S WAY	5/31/2017	1	
119	1 8226 01	113 LANE'S WAY	5/31/2017	1	
120	1 8228 01	130 LANE'S WAY	9/13/2017	1	
121	1 8227 01	324 JUPITER RD	10/1/2017	1	
122		2018			
123	2 1200 01	149 & 151 DIAMOND BACK RD	7/17/2018		2
124	1 9084 00	FAIRWAY ONE CONDOS - UPPER	8/5/2018		
125	1 9223 01	117 119 SENABI LANE	7/23/2018		2
126					
127	SUBTOTAL NEW CUSTOMER ACCOUNTS (ECU'S) ADDED SINCE 2005			71	68
128					
129					
130	130	Remaining Customers based on pipe in the ground	Sun Valley West Multi Family	Built 2012	180
131	131	Remaining Customers based on pipe in the ground	Sun Valley West Single Family	Built 2012	
132	132	Remaining Customers based on pipe in the ground	SV Symphony	Built 2008	16
133	133	Remaining Customers based on pipe in the ground	Lane Ranch North	Built 2013	4
134	134	Remaining Customers based on pipe in the ground	Lane Meadows	Built 2014	2
135	135	Remaining Customers based on pipe in the ground	Highlands	Built 2004	2
136	136	Remaining Customers based on pipe in the ground	Crown Ranch	Built 2004	11
137	137	Remaining Customers based on pipe in the ground	Elkhorn Springs	Built 2004	
138	138	Remaining Customers based on pipe in the ground	CKTK LLC	Built 2012	6
139	139	Remaining Customers based on pipe in the ground	Cold Springs Prop	Built 2012	28
140	140	Remaining Customers based on pipe in the ground	Rock Rolling	Built 2012	48
141	141	Remaining Customers based on pipe in the ground	Rock Rolling #2	Built 2012	12
142	142	Remaining Customers based on pipe in the ground	Jessen	Built 2012	1
143	143	Remaining Customers based on pipe in the ground	Schwartz	Built 2012	1
144					
145	SUBTOTAL REMAINING CUSTOMER ACCOUNTS (ECU'S BASED ON NEW PIPE IN THE GROUND) SINCE			15	111
146					
147					
148	NEW CUSTOMER ACCOUNTS (ECU'S) ADDED SINCE 2005 AND FUTURE CUSTOMERS ACCOUNTS (ECU'S BASED ON NEW PIPE IN THE GROUND) SINCE 2005			106	373
149					
150	TOTAL NEW CUSTOMER ACCOUNTS (ECU'S) ADDED SINCE 2005			179	
151					
152	PEAK HOUR DEMAND/ECU (gpm/ECU)			3.32	
153					
154	ADDITIONAL BENEFICIAL USE DEMAND SINCE 2005 (gpm)			1598	
155					
156					
157	Note: Equivalent Connection Units (ECU's) 2005 = 2.778				



SPARLING
INSTRUMENTS, LLC.
 4097 N. TEMPLE CITY BLVD.
 EL MONTE, CALIFORNIA 91731-1988 USA
 PH (800) 800-FLOW

SERIAL NO.
M207631617

SALES ORDER NO
58421

FLOW CALIBRATION TEST DATA SHEET FOR SERIES 600 FLOW METERS

CUSTOMER :	SUN VALLEY WATER/SEWER DISTRICT	OTHER PROGRAMMING PARAMETERS:	LOCKOUT OFF
ADDRESS :	SUN VALLEY, ID	FIRMWARE	2.40
MODEL NO. =	FM656-088-115-0	LINER.	FEP
TAG		ELECTRODES	SS
SIZE=	8 INCH	COIL FREQ=	3
INSIDE DIA. 'D'=	7.989 INCH	DISPLAY.	GPM
F. S. VELOCITY=	30.72 FPS	COUNT	FWD ONLY
F. S. RATE 'Q'=	4800 GPM 2500	REGISTR 'R'=	100 GAL
MTR CONST 'K' :	62.156 PULSES/GAL	OUTPUT	4-20MA
OFFSET =	0.453	ON-TIME	25 MS
SIGN	MINUS	FLOW DIR	FWD
		PASSWORD	0001

REMARKS: WATER, TEMP: AMB PRESSURE: MAX 150 PSI, AWWA CLASS D (150 PSI) FLANGES
 REMOTE 30' CABLE W/NEMA 4X ENCLOSURE, 316 STAINLESS STEEL GND RINGS
 77-265VAC REV: P: ;

TEST NO.	FLOW LAB DATA		FLOW METER DATA			AVERAGE FLOW IN GPM	AVERAGE VELOCITY FT/SEC	% ERROR OF RATE
	TIME SECS	WATER GALLONS	TOTAL PULSES	MTR CONSTANT PULSES/GAL	FREQ PULSES/SEC			
1	27.48	698.85	43438	62.156	1580.7	1525.87	9.77	
2	253.65	698.85	43553	62.321	171.7	165.31	1.06	
FLOW METER ACCURACY FOR THE FULL SCALE METER CONSTANT C= 12.5								
3	240.44	698.85	8722	12.481	36.3	174.39	1.12	-0.16%
4	88.87	698.85	8698	12.446	97.9	471.82	3.02	-0.43%
5	27.43	698.85	8709	12.462	317.5	1528.65	9.78	-0.30%
6								
7								

CALIBRATED BY: (07)
DATE: 04/25/17

CERTIFIED BY: (07)
DATE: 4/25/2017

FINALIZED BY: (04)
DATE: 4/25/2017

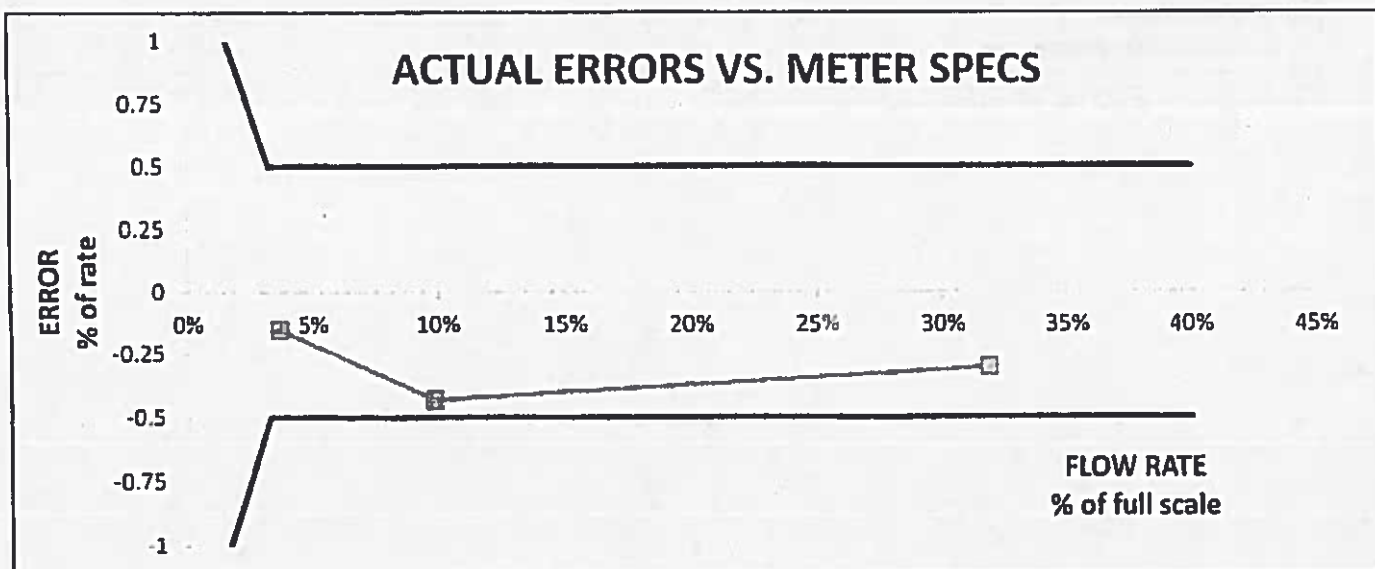

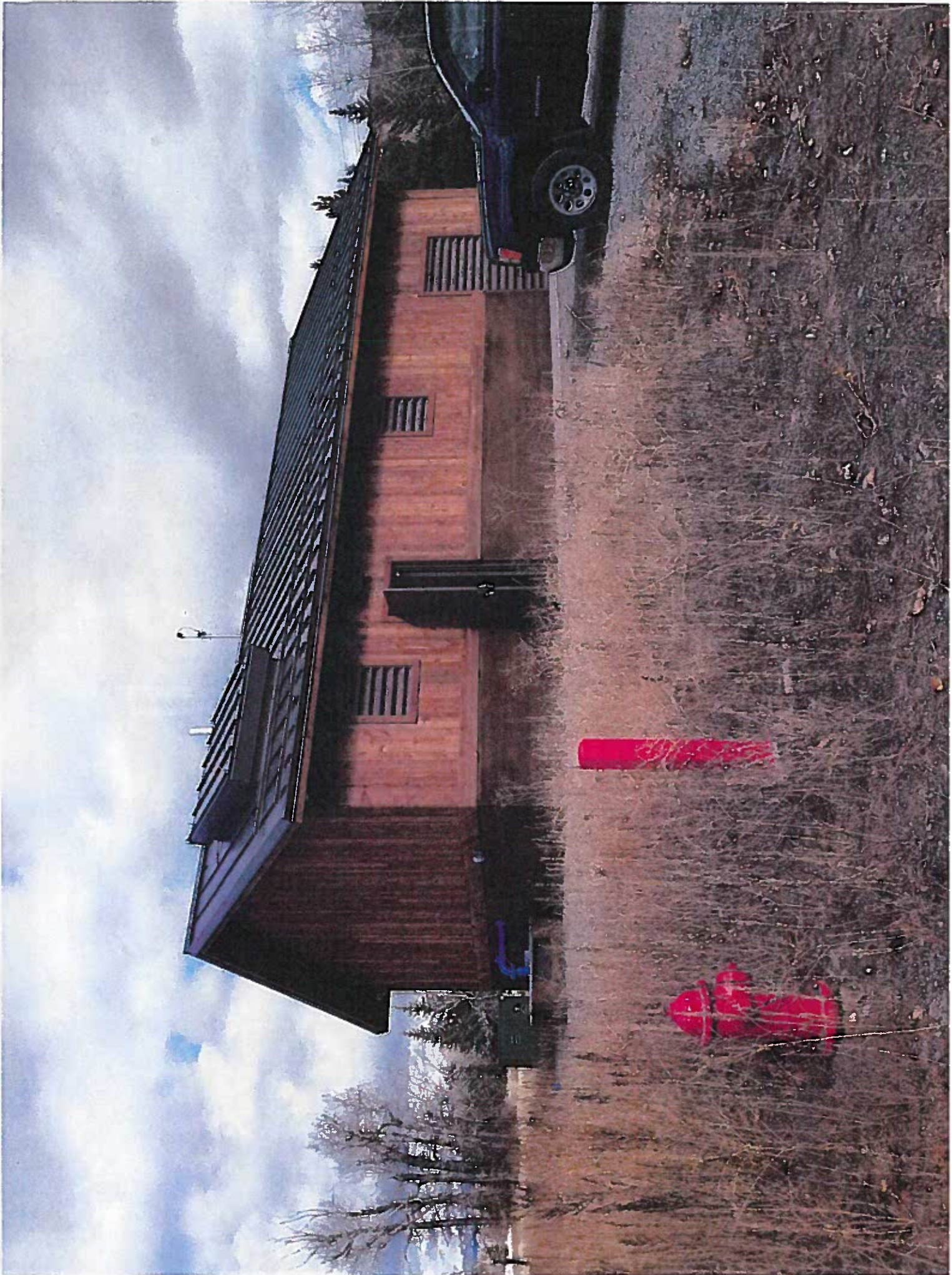





Well 13 Motor

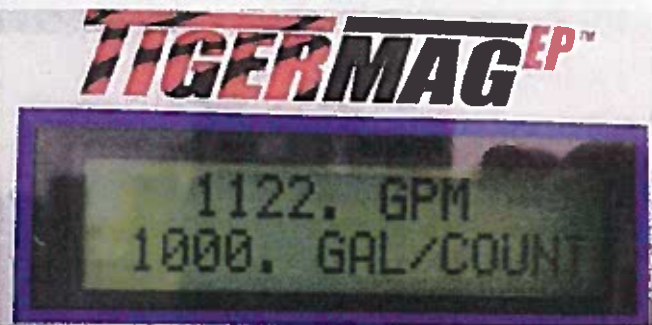

Meter and meter readout



Example of stubbed in service main

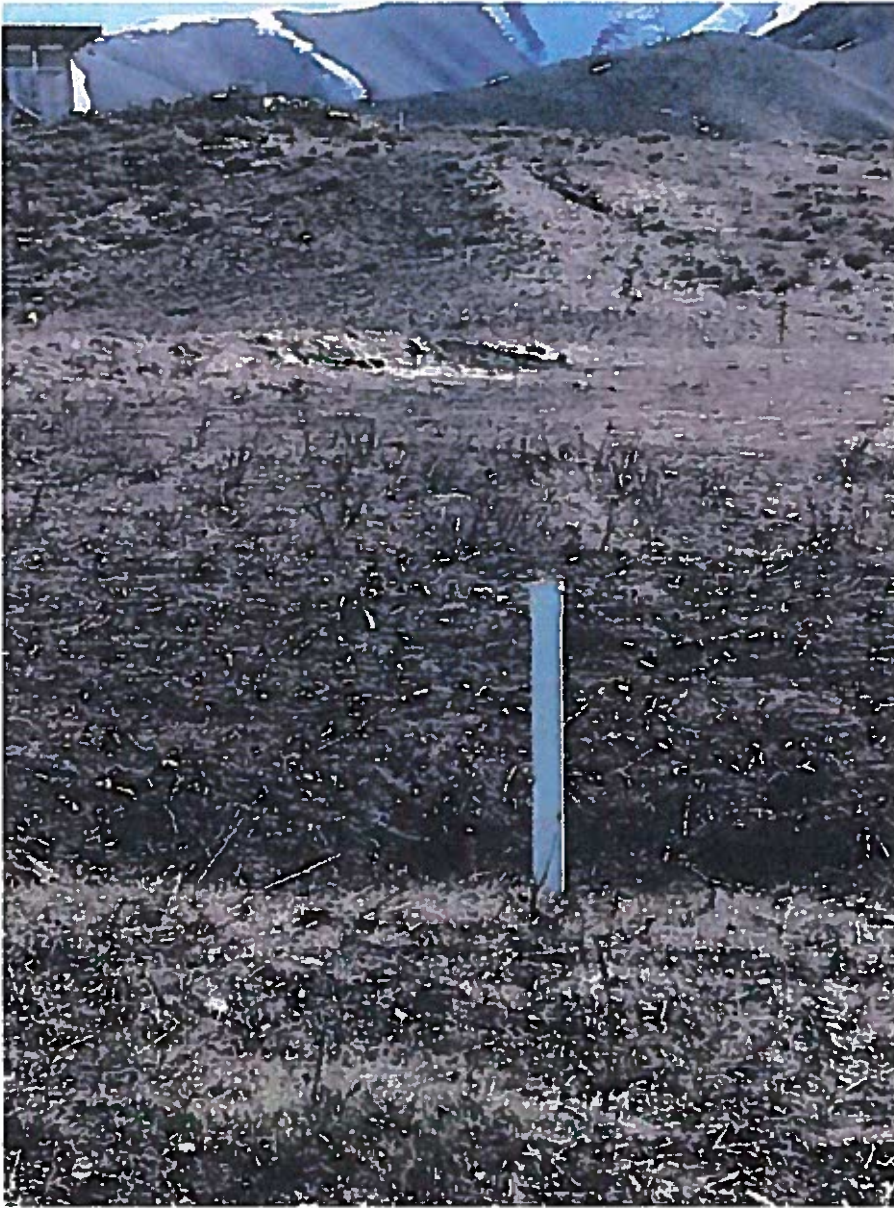

Example of stubbed in service line

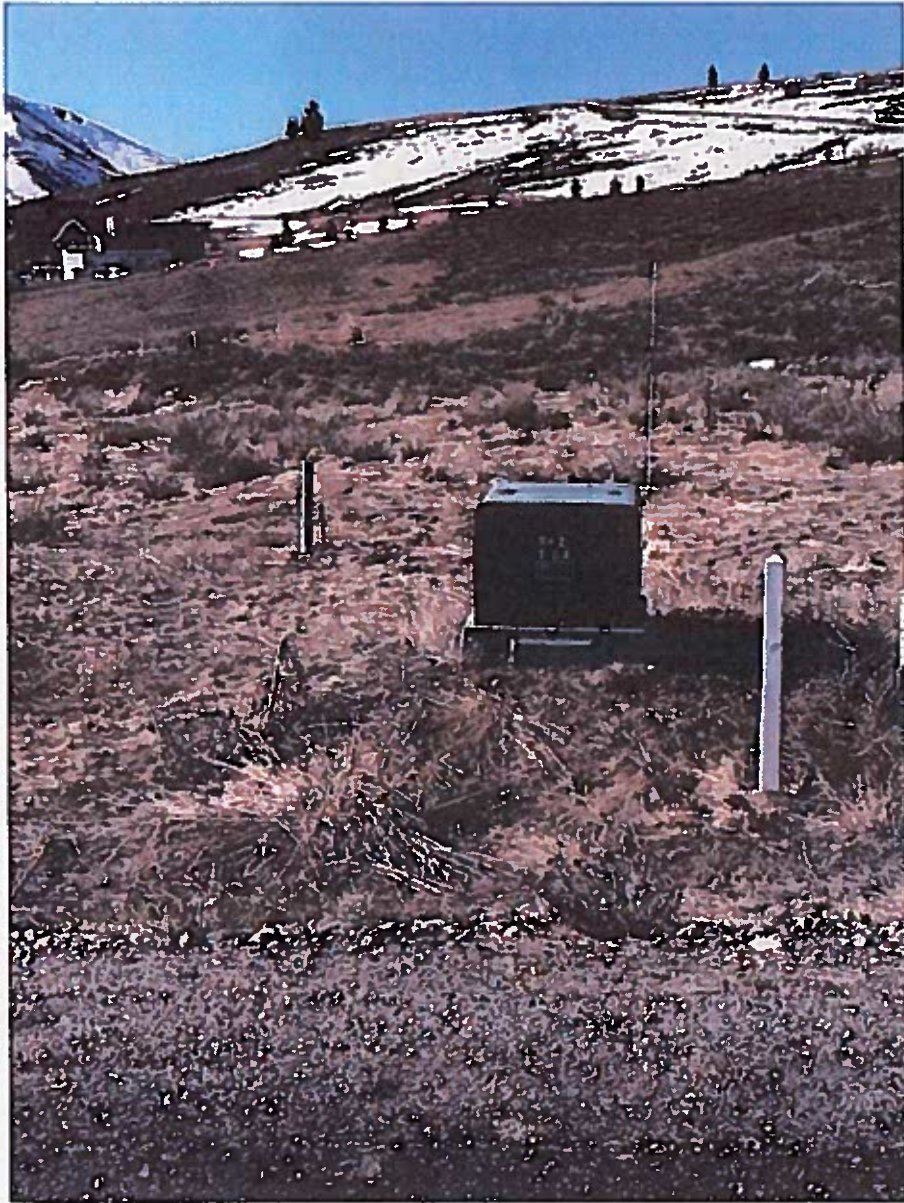

Example of stubbed in service line

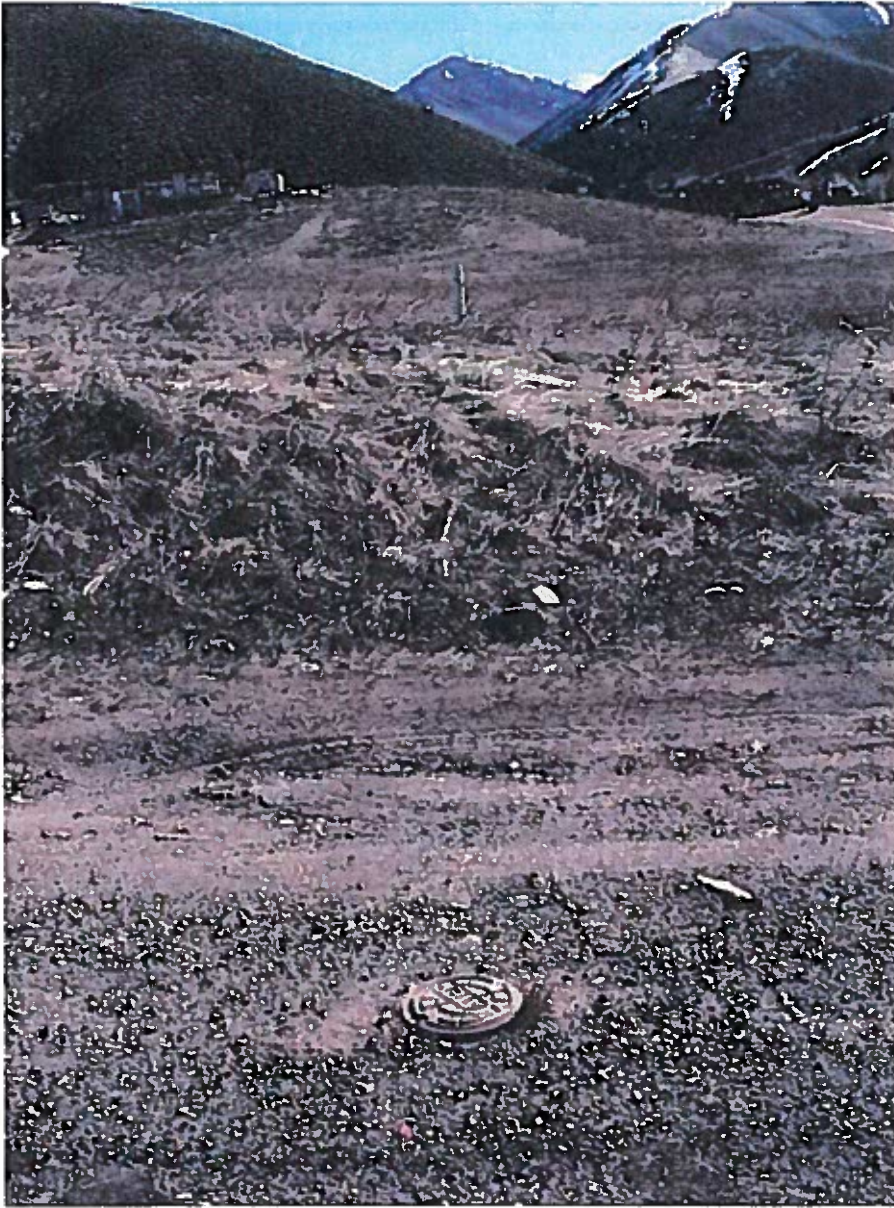

Example of stubbed in service main



TURBINE SUBMITTAL

Quote Number: 9001-170316-036:1
 Model: DWT-FFTM
 Size: 10DHHC 8 Stage(s)

OPERATING CONDITIONS

Temp / SG	70° F / SP.GR 1.00
Fluid Type	Water
Lubrication Method	Water (Open Lineshaft)
Vapor Pressure	0.3633 psi
Viscosity	0.9695 cP
Specified Flow	1000.00 USGPM
Total Dynamic Head	261.00 ft
Pumping Level	15.000 ft
TPL	41.000 ft
Sump/Pit Depth	0.000 ft
Documentation	Standard pump installation and operation manual and order data

PERFORMANCE AT 1770 RPM

Bowl Efficiency	78.30 @design, 80.00 Best Efficiency
Run Out Capacity	1176.00 USGPM
Power	84.30 @design, 89.70 NOL (Hp)
Npshr	15.90 ft @design
Design Thrust	3395.80 @design (lb)
Shut off Pressure	165.35 psi

MATERIALS AND DIMENSIONS

Bowl	Cast iron with glass enamel		
Suction Bowl	Cast Iron CL30		
Bowl Wear Ring	Bronze, AL C95400		
Impeller	Silicon Bronze C87610		
Impeller Diameter	6.1875 inch		
Impeller Wear Ring	Not Included		
Impeller Balance	Dynamic Two-Plane Balance		
Impeller Lock Method	Taper lock	Key Material	None
Bowl Shaft	416SS, 1.6875 inch diam.		
Suction Bearing	Bronze C90300 "G" Modified		
Bowl Bearings	Bronze C90300 "G" Modified		
Rifled Drill Shaft	No		
Collets	Carbon steel		
Strainer Type	Galvanized Steel Cone Strainer		
Tube Bearing Adapter Material	Not Included		
Column	Carbon Steel, 8" [203mm] (in) diam., 23.01 ft, Threaded		
Column Shaft Diameter	416SS, 1.1875 (in) diam.		
Column Bearing Retainer	304SS		
Lineshaft Bearings	Rubber EPDM		
Column Bearing Options	Not Included		
Max Bearing Space	10 ft (3 m) Spacing		
Lineshaft Coupling	416SS		

DO NOT USE FOR CONSTRUCTION UNLESS CERTIFIED

Certified by	
Date of certification	
Pump serial number	
Project Name	Sun Valley Well 13
Tag:	



TURBINE SUBMITTAL

Quote Number: 9001-170316-036:1
 Model: DWT-FFTM
 Size: 10DHHC 8 Stage(s)

Column Shaft Sleeve	304SS
Tube Material	Carbon Steel
Discharge Head	Carbon Steel Fab
Discharge Head Style	FF
Discharge Flange	8" [203mm] (in), 150#
Head Shaft Coupling	416SS Threaded
Steel Sub Base	Carbon Steel
150# Disch Companion Flange	Not Included
300# Disch Convenience Flange	Not Included
Head Bolting	316SS
Head Sleeve	416SS Hard Faced
Thrust Pot	Not Required
Sealing Method	Packing
Packing	Chesterton SuperSet SpiralTrack
Mechanical Seal	Not Included
Sealing Features	

DRIVER INFORMATION

Motor Type	Standard
Motor Manufacturer	US Motors
Rating	100 Hp [75 kW]
Efficiency Level	PREM
Motor Part Number	H100S2A1GD-WVNU-000A0C000
Enclosure	WPI
Phase / Frequency / Volts	3 / 60 Hz / 460PWS
Speed	1800 RPM

TESTING

Hydrostatic:	Hydrostatic Testing (Non-Witness): Bowl
Performance:	Full Speed Performance Testing (Non-Witness): Lab Motor, Bowl Assembly
Vibration:	Vibration Testing (Non-Witness)
NPSH:	None
Post Inspection:	None
Final Inspection:	None
Other:	3 hour run

COATING

Coating Information: Tnemec 141; 8 mils; Bowl Assembly - OD; Column Assembly - OD and ID; Head Assembly - OD and ID

ADDITIONAL FEATURES

Additional Bowl Features	3 hour performance test
Additional Column Features	304SS Shaft Sleeves
Additional Head Features:	416SS Hard-faced Headshaft Sleeve (1) 1.25" Tapped Hole in Baseplate

DO NOT USE FOR CONSTRUCTION UNLESS CERTIFIED

Certified by	
Date of certification	
Pump serial number	
Project Name	Sun Valley Well 13
Tag:	



TURBINE SUBMITTAL

Quote Number: 9001-170316-036:1
 Model: DWT-FFTM
 Size: 10DHHC 8 Stage(s)

Additional Driver Features: (1) 1" Tapped Hole in Baseplate with plug
 (1) 0.5" Tap for Pressure Gauge
 Stock Conversion Adder - Thermistors
 Stock Conversion Adder - Therma Sentry (control for Thermistors)
 Stock Conversion Adder - Complete Initial Test
 Stock Conversion Adder - Torsional Analysis

Additional Can features: Critical Speed Analysis (± 20%)
 Reed Critical Frequency Analysis

Additional Misc features: NSF 61 Certified
 Certificate of Compliance
 Spare packing set

WEIGHTS

Total bowl weight	603 lb
Total column weight	825 lb
Discharge head weight	573 lb
Driver weight	1110 lb
Approximate net weight	3111 lb

Our offer does not include specific review and incorporation of any Statutory or Regulatory Requirements and the offer is limited to the requirements of the design specifications. Should any Statutory or Regulatory requirements need to be reviewed and incorporated then the Customer is responsible to identify those and provide copies for review and revision of our offer.

Our quotation is offered in accordance with our comments and exceptions identified in our proposal and governed by our standard terms and conditions of sale – Xylem Americas attached hereafter.

For units requiring performance test, all performance tests will be conducted per ANSI/HI 14.6 standards unless otherwise noted in the selection software submittal documents. Test results meeting with grade 2B tolerances for pumps with a rated shaft power of 134HP or less and grade 1B for greater than 134HP will be considered passing.

Customer is responsible for verifying that the recommendations made and the materials selected are satisfactory for the Customer's intended environment and Customer's use of the selected pump. Customer is responsible for determining the suitability of Xylem recommendations for all operating conditions within Customer's and/or End User's control. Xylem disclaims all warranties, express or implied warranties, including, but not limited to, warranties of merchantability and fitness for a particular purpose and all express warranties other than the limited express warranty set forth in the attached standard terms and conditions of sale – Xylem Americas attached hereafter.

Xylem does not guarantee any pump intake configuration. The hydraulic and structural adequacies of these structures are the sole responsibility of the Customer or his representatives. Further, Xylem accepts no liability arising out of unsatisfactory pump intake field operating conditions.

The Customer or his representatives are referred to the Hydraulic Institute Standards for recommendations on pump intake design. To optimize the hydraulic design of a field pump intake configuration, the Customer should strongly consider performing a detailed scale model pump intake study. However, the adequacies of these recommendations are the sole responsibility of the Customer.

DO NOT USE FOR CONSTRUCTION UNLESS CERTIFIED	
Certified by	
Date of certification	
Pump serial number	
Project Name	Sun Valley Well 13
Tag:	

OUTLINE DRAWING

Quote Number: 9001-170316-036:1
Model: DWT-FFTM
Size: 10DHHC 8 Stage(s)

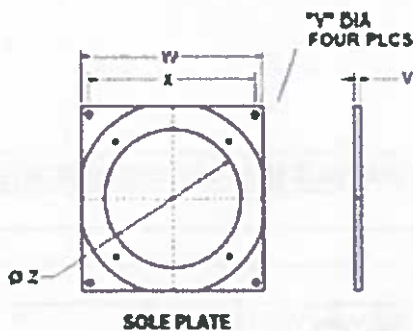
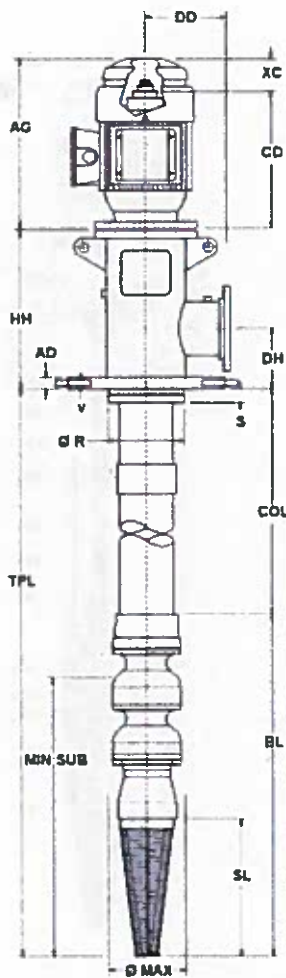
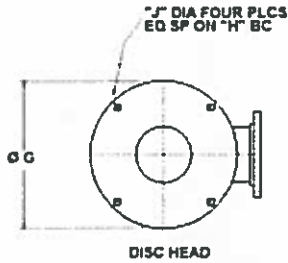

DIMENSIONS

AD	1.63	inch
AG	42.69	inch
BD	16.5	inch
BL	104.31	inch
CD	36.94	inch
COL	387.69	inch
DD	15.50	inch
MIN SUB	38.50	inch
DH	9.50	inch
G	23.50	inch
H	21.25	inch
HH	30.00	inch
J	1.13	inch
R	12.25	inch
S	2.06	inch
SL	11.94	inch
TPL	492.00	inch
V	1.00	inch
W	23.50	inch
X	20.50	inch
XC	5.50	inch
Y	1.00	inch
Z	16.25	inch
Max Dia	9.50	inch
Discharge	(150 #) 8	inch

Weights

Total bowl	603	lb
Total column	825	lb
Discharge head	573	lb
Driver	1110	lb
Approx weight	3111	lb

PUMP DATA

No. of Units	1.00
Model:	DWT-FFTM 10DHHC
Stages:	8
Col Size:	8" [203mm]
Shaft:	1.1875 in dia
Flow:	1000.00 USGPM
Head:	261.00 ft
Driver Mfr:	US Motors
Driver Type:	VHS
Rating:	100 Hp [75 kW]
Speed:	1800 RPM
Phase:	3
Frequency:	60 Hz
Voltage:	460PWS

No.	NOTES
1	Total Pump Length ± 1.0 inch.
2	Tolerance on all dimensions is .12 or ± .12 inch per 5 ft, whichever is greater.
3	All dimensions shown are in inches unless otherwise specified.
4	Drawing not to scale.
5	1/2" NPT - Gauge Conn (plugged)
6	Driver may be rotated at 90° intervals about vertical centerline for details refer to driver dimension drawing.
7	Refer to product IOM for impeller setting requirements.
8	This assembly has been designed so that its natural frequency responses avoid the specific operating speeds by an adequate safety margin. The design has assumed the foundation to be rigid.

DO NOT USE FOR CONSTRUCTION UNLESS CERTIFIED

Certified by	
Date of certification	
Pump serial number	
Project Name	Sun Valley Well 13
Tag	

BILL OF MATERIAL

ITEM	Part Name	CODE	MATERIAL	ASTM#
Discharge Head Assembly				
600	Head – Discharge	9645	Carbon Steel Fab	A53
602	Head – Base Plate	3201	Carbon Steel	A36M-00a
604	Nut – Adjusting	2242	Carbon Steel 1018	A108-99
608	Headshaft	2227	416SS	A582M-95b
616	Housing	1003	Cast Iron CL30	A48-94-ae1
617	Bearing-Housing	1109	Bronze C90300 "G" Modified	B584-00
618	Gland-Split	1203	316SS	A744M-00
620	Packing	5026	Acrylic yarn and graphite	ML402-99
621	O-Ring	5302	Nitrile Buna N	D4322-96
622	Slinger	5121	Rubber EPDM	D3568-98
648	Head Sleeve	6711	416SS Hard Faced	A582M-95b
730	Key-Motor Gib	2242	Carbon Steel 1018	A108-99
757	Screw-Gland Adj	2229	SST 316	A276-00a
Column and Lineshaft Assembly				
637	Hanger Flange	1003	Cast Iron CL30	A48-94ae1
642	Column Pipe	9645	Carbon Steel	A53
645	Column-Coupling	9645	Carbon Steel	A53
646	Lineshaft	2227	416SS	A582M-95b
649	Lineshaft Coupling	2265	416SS	A582M-95b
652	Retainer-Bearing	1205	304SS	A744M-00
656	Lineshaft Bearing	5121	Rubber EPDM	D3568-98
Bowl Assembly				
660	Bowl-Shaft	2227	416SS	A582M-95b
664	Bearing – Disc Bowl	1109	Bronze C90300 "G" Modified	B584-00
670	Bowl-Inter	6911	Cast Iron CL30 Enamel	A48-94e1
672	Bearing-Int Bowl	1109	Bronze C90300 "G" Modified	B584-00
673	Impeller	1398	Silicon Bronze C87610	B584-00
677	Collet-Impeller	2242	Carbon steel	A108-99
674	Key-Impeller	N/A	None	N/A
680	Wear Ring-Bowl	1128	Bronze, AL C95400	B148-97e1
681	Wear Ring-Impeller	N/A	Not Included	N/A
688	Bowl-Suction	690	Cast Iron CL30	1003
690	Bearing-Suction	1109	Bronze C90300 "G" Modified	B584-00
692	Sandcollar	1205	304SS	A744M-00
698	Cone Strainer	6952	Galvanized Steel	A123
747	Plug-Pipe	1046	Malleable Iron	A197
760	Capscrew-Hex	2229	316SS	A276-00a

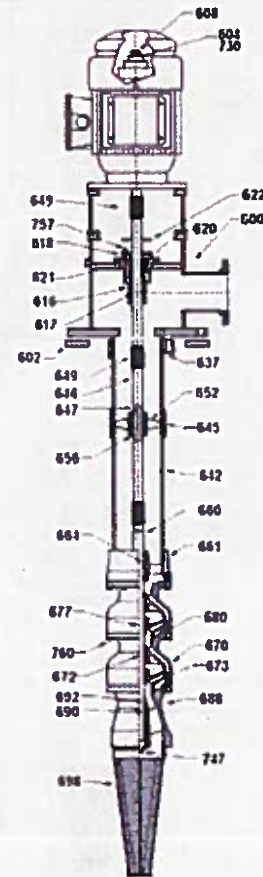

DO NOT USE FOR CONSTRUCTION UNLESS CERTIFIED	
Certified by	
Date of certification	
Pump serial number	
Project Name	Sun Valley Well 13
Tag	

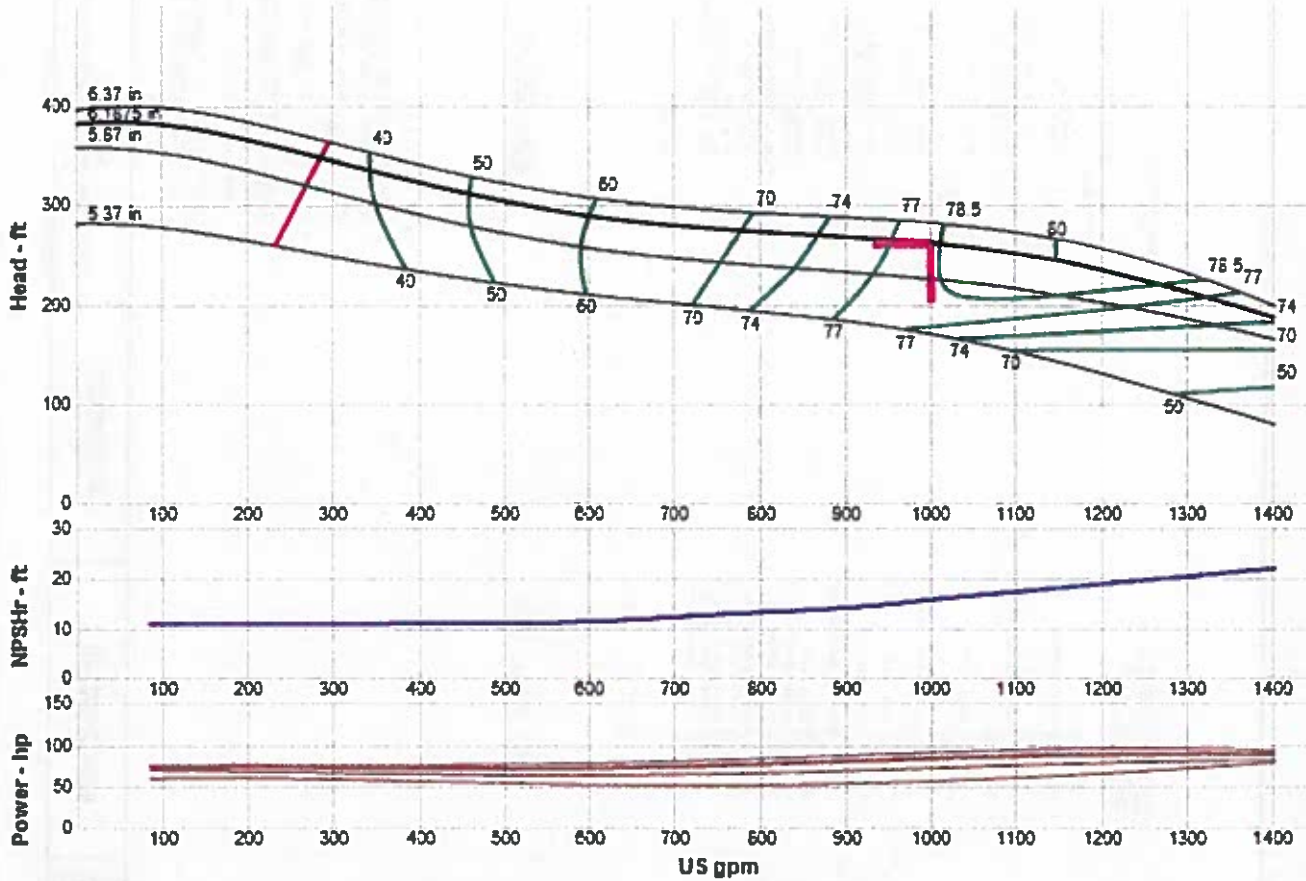

Driver Size Criteria:
Speed: 1770
Impeller Trim: 6.1875 inch
Frequency: 60 Hz
Additional Impeller Trim: 6.188 inch
Impeller Maximum Trim: 6.3700 inch
Specified Flow: 1000.00 USGPM
Specified Head: 260.00 ft
Head at Design: 261.00 ft
Efficiency at Design: 78.30 %
Power at Design: 84.30 Hp
Flow on Design Trim at Max Power: 1321 USGPM
Max Power on Design Curve: 89.70 Hp
Run-Out Flow: 0.00 USGPM
Run-Out Head: 0 ft

Max power on design curve (NOL)
Best Efficiency:
Flow at BEP:
Min Flow:
Derate Factor:
NPSH Required:
NPSH Actual:
Shut-Off Head:
Fluid Type:
Temperature / Specific Gravity:
Viscosity:
Allowable Sphere Size:
Thrust K Factor:
Additional Thrust K Factor:
Max Lateral:

80.00 %
1145.00 USGPM
286.00 USGPM
0.0000
15.90 ft
47.80 ft
382.00 ft
Water
70°F / 1.00
0.9695 cP
0.47 inch
12.4000 lbs/ft
12.4000 lbs/ft
0.75 inch

DO NOT USE FOR CONSTRUCTION UNLESS CERTIFIED

Certified by

Date of certification

Pump serial number

Project Name

Sun Valley Well 13

Tag

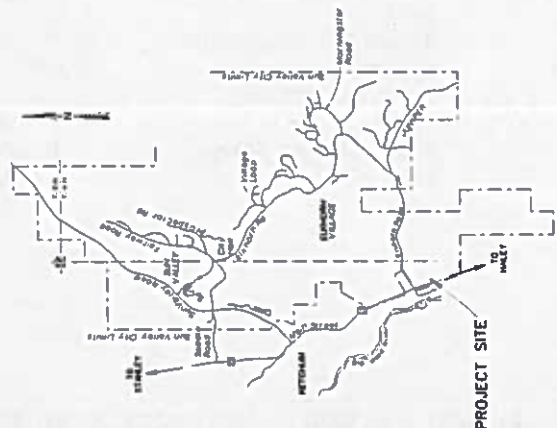

VICINITY MAP
MS

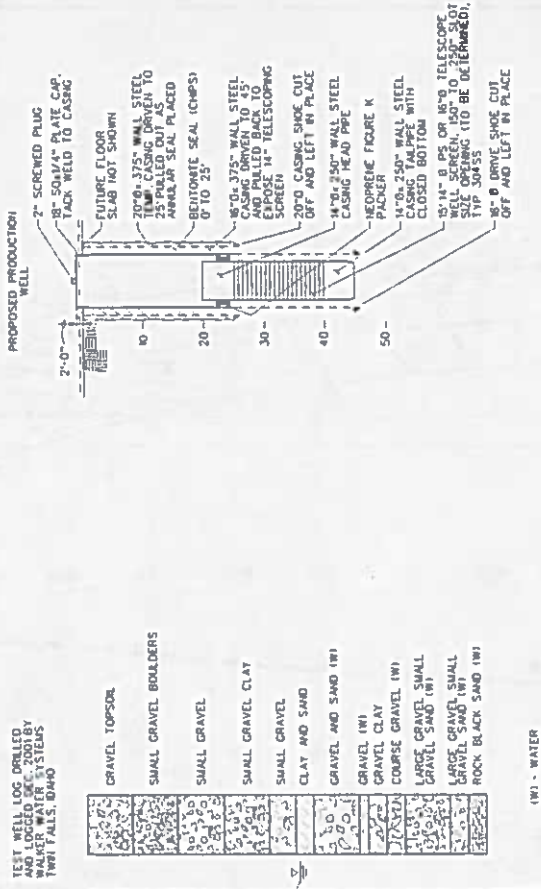

TEST WELL LOG
MS

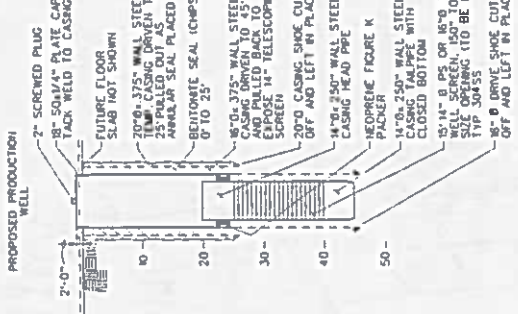

WELL DETAIL
MS

DESIGN NOTES:
 1. BASED ON CH2M HILL TECHNICAL MEMORANDUM OF TEST WELL RESULTS, OCTOBER 14, 2004. WELL PRODUCTION GOAL IS BETWEEN 600 AND 800 GALLONS PER MINUTE.
 2. WELL IS DESIGNED FOR MAXIMUM EFFICIENCY, LARGE DIAMETER, NATURAL GRAVEL PACK DEVELOPMENT.
 3. DRILLING METHODS USED MUST BE CAPABLE OF PULLING 18" AND 20" CASING.
 4. SANITARY SEAL BENEATH SOLIDS (CH2S) DUE TO STRONG LIKELIHOOD OF LOSING SLURRIES INTO SHALLOW GRAVELS.
 5. VICEROUS DEVELOPMENT WILL BE REQUIRED.
 6. WELL TO CONFORM TO IDAHO 37, TITLE 03 CHAPTER 09, WELL CONSTRUCTION STANDARD RULES, IDAHO 58, TITLE 01 CHAPTER 08, IDAHO RULES FOR PUBLIC DRINKING WATER SYSTEMS, AND APPROVED BY IDAHO DEC.



NO.	REVISION	NO. DATE	NO. DATE
1			

DESIGNER: J. WARRICK
 CHECKER: J. BROOKER
 DATE: 12/05/04

APPROVED BY: J. WARRICK

PROJECT: SANITARY WATER AND SEWER DISTRICT STATION FOR WELL NO. 10

SCALE: AS SHOWN IN PLOT
 VERIFY SCALE: AS SHOWN IN PLOT
 DATE: 12/05/04

CH2MHILL

WELL NO. 13
 VICINITY MAP, TEST WELL AND WELL DETAIL

SHEET	1 OF 2
DATE	JULY 2008
PROJECT	150407



THIS DOCUMENT AND THE REAR AND DESIGN INCORPORATED HEREIN AS AN INSTRUMENT OF PROFESSIONAL SERVICE IS THE PROPERTY OF CH2MHILL. IT IS NOT TO BE USED, IN WHOLE OR IN PART, FOR ANY OTHER PROJECT WITHOUT THE WRITTEN AUTHORIZATION OF CH2MHILL.



DESIGNER CH2MHILL 4728 CHAD L. BROOKS P.E.	NO. DATE 1 11/11/08	DESCRIPTION REVISION	APPROVED BY M. [Signature]	VERIFY SCALE MAKE ONE COPY FOR ORIGINAL DRAWING IF NOT ONE COPY OF THIS PROJECT, OBTAIN FROM PROJECT ARCHIVE	CH2MHILL	SITE VALLEY WATER AND SEWERAGE TREATMENT PLANT FOR WELL NO. 13	WELL NO. 13 SITE PLAN	SHEET DWG DATE 11/11/08	2 OF 2 PLOT TIME: 14:00
--	---------------------------	-------------------------	-------------------------------	---	-----------------	--	-----------------------	----------------------------------	----------------------------

FILE NAME: PLOT DATE:

DEC-15-2006 01:54P FROM: 2087360795 TO: 12083455315 P.1



SINCE 1947

WALKER WATER SYSTEMS, INC.

624 Pierce Street • Twin Falls, Idaho 83301
(208) 733-4744 • (208) 726-5145 • Fax 736-0795

DATE: 12/15/06

F A X M E S S A G E

FROM: Cynthia Poffin, Walker Water Systems, Twin Falls, Idaho

TO: John Walker

Number of Pages, Including Cover Page: 3

Comments: 345-5315

Thank You



SINCE 1947
WALKER WATER SYSTEMS, INC.

624 Pierce Street • Twin Falls, Idaho 83301
208-733-4744 • 208-726-5145

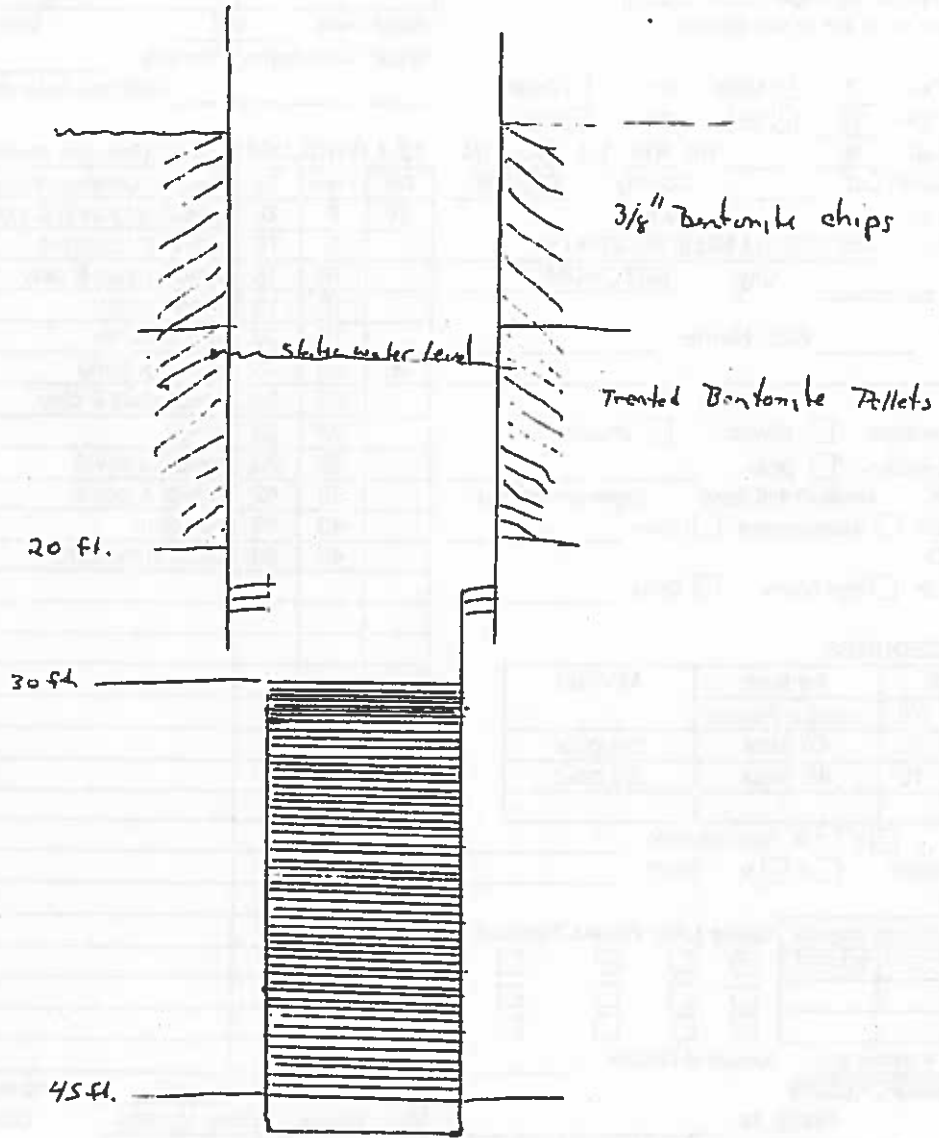

1. WELL TAG NO. D - 0042946
DRILLING PERMIT NO. 842799

Other IDWR No. 37-21465

2. OWNER

Name SUN VALLEY WATER & SEWER DIST.
Address P.O. BOX 2410
City SUN VALLEY State ID Zip 83353

3. LOCATION OF WELL by legal description:

Sketch map location must agree with written location

Map grid with coordinates: Twp. 3 North or South, Rge. 18 East or West, Sec. 30, County BLAINE. Includes latitude and longitude fields.

Address of Well Site HWY 75 1/4 MILE SOUTH OF ELKHORN RD City KETCHUM

Lt. Blk. Sub. Name

4. USE:

Domestic, Municipal, Monitor, Irrigation, Thermal, Injection, Other

5. TYPE OF WORK check all that apply (replacement ect.)

New Well, Modify, Abandonment, Other

6. DRILL METHOD

Air Rotary, Cable, Mud Rotary, Other

7. SEALING PROCEDURES

Table with columns: Seal/Filter Pack, Amount, Method. Rows include bent pellet and bent chips.

Nas drive shoe used? y N Shoe depth(s)

Nas drive shoe seal tested? Y N How?

8. CASING/LINER

Table with columns: Dia, From, To, Gauge, Material, Casing, Liner, Welded, Threaded. Row 1: 16, 3, 28, 375, STEEL.

Length of Headpipe 4' packer yes Length of Tailpipe

9. PERFORATIONS/SCREENS

Perforations Methods Screens Screen Type STAINLESS STEEL

Table with columns: From, To, Slot Size, Number, Diameter, Material, Casing, Liner. Row 1: 30, 45, 100, 14 OD, S STEEL.

10. STATIC WATER LEVEL OR ARTESIAN PRESSURE:

12 ft below ground Artesian pressure Depth flow encountered ft. Describe access port or control devices

11. WELL TESTS:

Pump, Bailer, Air, Flowing Artesian

Table with columns: Yield gpm, Drawdown, Pumping Level, Time. Row 1: 1247, ± 15 ft, 26-30, 7 hrs.

Water Temp. 48° Bottom hole temp.

Water Quality test or comments: Depth first water encounter

12. LITHOLOGIC LOG: (Describe repairs or abandonment)

Large table with columns: Dia, From, To, Remarks, Water Y/N. Contains detailed lithology log entries.

Completed depth 46 ft. (measurable)

Date: Started October 16, 2006 Completed November 22, 2006

13. DRILLERS CERTIFICATION

We certify that all minimum well construction standards were complied with at the time the rig was removed.

Company Name WALKER WATER SYSTEMS Firm No. 15

624 PIERCE ST. TWIN FALLS, ID 83301

Firm Official and Date 12/15/06

Driller or Operator Date (Sign once if Firm Official & Operator)

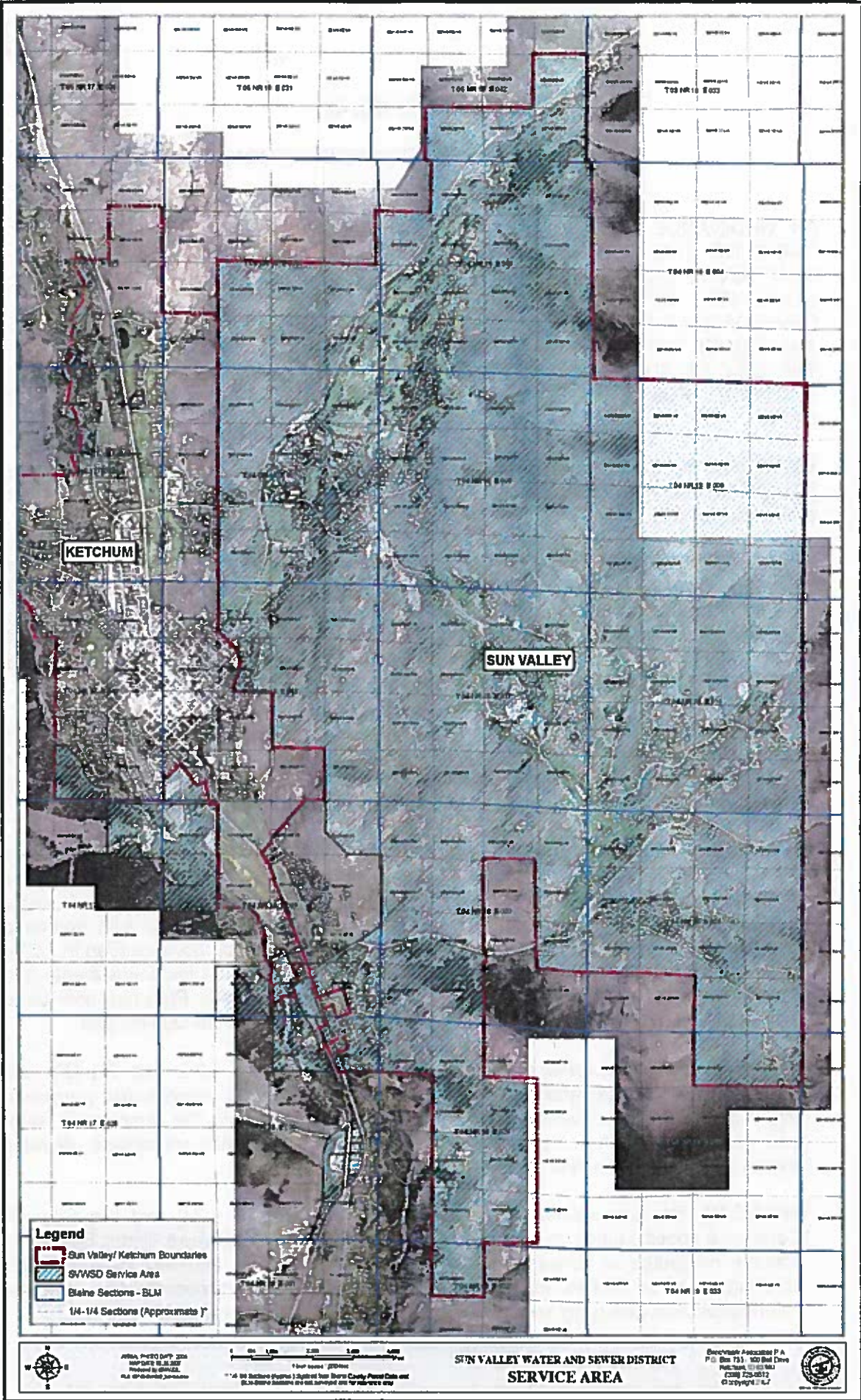

ORDINANCE NO. 421

WATER CONSERVATION REGULATIONS

AN ORDINANCE OF THE CITY OF SUN VALLEY, BLAINE COUNTY, IDAHO, AMENDING THE SUN VALLEY DEVELOPMENT CODE BY REVISING TITLE 9, CHAPTER 3, ARTICLE A, SECTION 3 (CODE SECTION 9-3A-3), EVALUATION STANDARDS, BY REQUIRING SITE AREA IRRIGATION LIMITATIONS FOR NEW DEVELOPMENT ON A LOT OR PARCEL SERVED BY THE SUN VALLEY WATER AND SEWER DISTRICT AND WITHIN THE RESIDENTIAL ZONING DISTRICTS OF THE CITY OF SUN VALLEY; BY PROVIDING FOR A SEVERABILITY CLAUSE; BY PROVIDING FOR A REPEALER CLAUSE; AND BY PROVIDING AN EFFECTIVE DATE.

WHEREAS, the City of Sun Valley has adopted the 2005 Comprehensive Plan Update (*Comprehensive Plan*) by Resolution 2005-12, on September 8, 2005, and subsequent amendments; and

WHEREAS, the *Comprehensive Plan* serves as a guiding document and contains the goals, objectives, guidelines and policies for the immediate and long range protection of the City's natural and scenic resources, the environment, open spaces, aesthetic quality, privacy, and quality of life. The *Comprehensive Plan* more specifically includes identified Action Items that broadly seek to promote partnership with the Sun Valley Water and Sewer District and promote water conservation goals; and

WHEREAS, the domestic water and irrigation needs of the City of Sun Valley are met primarily by the Sun Valley Water and Sewer District which is not an agency or department of the City. The City and the District share largely the same jurisdictional area but more importantly maintain close ties with similar goals and purposes; and

WHEREAS, the *Comprehensive Plan* states that forecast models of the Sun Valley Sewer and Water District indicate that adequate domestic water is available for additional growth in the City of Sun Valley but may require a concerted water conservation program for irrigation of existing and/or new landscaping with domestic water supplies. At the time of writing and adoption of the *Comprehensive Plan* in 2005, the District was updating water availability studies to help guide District investments and to systematically prepare for future growth. The District's Master Plan has now been completed and accepted by the Idaho Department of Environmental Quality; and

WHEREAS, the *Comprehensive Plan* states in Action Item 1.3.2 that the City will "Develop water conservation measures for landscaping and recreational purposes, including golf course development and operations, that reduce the quantity of water used through irrigation and evaporation technologies and, where appropriate, develop incentives to use gray and/or untreated water."; and

WHEREAS, the *Comprehensive Plan* states in Action Item 4.2.8 that the City will "Conduct a specific study, in partnership with the Sun Valley Sewer & Water District, to evaluate measures to conserve water resources for existing and new developments including, but not limited to, metering, low-water landscape consumption, low-use watering technologies, gray water use, and a public education program."; and

WHEREAS, the *Comprehensive Plan* states in Action Item 5.2.1 that the City will "Work with Sun Valley Water & Sewer District to ensure that sufficient wastewater treatment capacity, a sufficient, high quality domestic water supply, and necessary levels of firefighting water supply are available for existing and future use."; and

WHEREAS, the *Comprehensive Plan* states in Action Item 8.2.4 that the City will "Cooperate with the Sun Valley Water & Sewer District Board to 1) ensure that adequate supplies of high-quality domestic water and waste treatment capacities are sufficient for current and future build-out of the densities zoned for the City, the proposed Areas of City Impact, and the region and 2) initiate supplemental studies, as necessary, on water quality surveys, sewer upgrades, and water conservation."; and

WHEREAS, the waters of the State of Idaho are of limited supply and subject to ever increasing demands; and

WHEREAS, the continuation of Sun Valley's economic prosperity and safety is dependent on adequate supplies of water being available for future development use and fire protection purposes; and

WHEREAS, the use of all waters within the State of Idaho are under increased scrutiny with threats of curtailment; and

WHEREAS, the *Comprehensive Plan* states that the Sun Valley Water and Sewer District has informally asked the City to consider water conservation methods in planning activities to better manage water resources. In the years ensuing the adoption of the *Comprehensive Plan*, the District has been discussing and formulating policy and action on potential water conservation programs that could be implemented by the District directly or with assistance from the City; and

WHEREAS, the Sun Valley Water and Sewer District and the City of Sun Valley were presented with the background research completed by Clemens Associates Inc working on behalf of the District to examine existing water use patterns and existing development. The existing water use analysis and lot by lot subdivision data for single and multi family development within the City of Sun Valley and the District formed the justification for the site area irrigation limitation and was developed through three publicly noticed workshops by the District Board on March 9, March 26 and April 21, 2009; and

WHEREAS, in May, 2009 the Sun Valley Water and Sewer District formally requested that the City of Sun Valley go forward with an amendment to the Development Code to limit site area irrigation for new development on lots and parcels served by the District and within a residential zoning district of the City; and

WHEREAS, Development Code Section 9-3A establishes Design Review Regulations to ensure that development is designed and built in a manner that is context sensitive, complimentary to adjacent property, protects the natural landscape, is of high design quality, and is compatible with the character and scale of the neighborhood. Code Section 9-3A-3, Evaluation Standards, establishes criteria which shall be used in evaluating proposed developments seeking design review approval, including design and siting, grading, architectural quality, pedestrian and vehicle circulation design, landscape quality, etc.; and

WHEREAS, the Planning and Zoning Commission of the City of Sun Valley met the provisions of the City of Sun Valley Development Code and Idaho Code 67-6509 with a properly noticed public hearing for the purpose of reviewing the proposed amendments to Development Code Section 9-3A-3 for site area irrigation limitations for new development on a lot or parcel served by the Sun Valley Water and Sewer District and within the residential zoning districts of the City of Sun Valley at their June 11, June 25 and August 13, 2009 regular meetings and passed a motion recommending approval of draft Ordinance 421 to the City Council; and

WHEREAS, the City Council of the City of Sun Valley held a properly noticed public hearing in accordance with Idaho and City Codes on November 12 and December 17, 2009 and January 21, 2010 to consider the Planning and Zoning Commission's recommendation on Ordinance No. 421, take public and applicant testimony, and consider the findings for taking action on the Development Code Amendment.

NOW, THEREFORE; THE MAYOR AND THE CITY COUNCIL OF THE CITY OF SUN VALLEY, IDAHO, DO ORDAIN AS FOLLOWS:

SECTION 1. FINDINGS- Based on the statements above the City Council for the City of Sun Valley adopts the following findings regarding amendments to the Development Code:

1. The text amendment complies with all applicable provisions of the *Comprehensive Plan* by implementing the stated goals and specific action items regarding water conservation.
2. The text amendment is not materially detrimental to the public health, safety and welfare because water conservation would act to benefit water availability for future development needs and fire protection activities.
3. The text amendment does not result in an adverse impact on the delivery of services by any political subdivision providing public services within the City including, but not limited to, school districts. The text amendment will assist the Sun Valley Water and Sewer District to provide adequate water supplies to the properties it serves within the City of Sun Valley.

SECTION 2. DEVELOPMENT CODE AMENDMENT- The City of Sun Valley adds the following amendment to the text of Municipal Code Section 9-3A-3 by inserting it as new Subsection F and re-lettering the ensuing existing Subsections F, G, H and I to read G, H, I and J, for the reasons and purposes contained above:

9-3A-3F IRRIGATION LIMITS

- A. *In order to fairly distribute available domestic irrigation water to all residential lots and parcels served by the Sun Valley Water & Sewer District, the total area of any lot or parcel irrigated with Sun Valley Water and Sewer District water shall not exceed the following:*
 1. *For RA & RS-1 Single-family lots, the total area of all irrigated portions of the lot or parcel shall not exceed 22,000 square feet (approximately ½ acre).*

2. For RS-2 Cluster Single Family Development parcels, and for RM-1 and RM-2 Multiple Family Development parcels, the total area of all irrigated portions of the development parcel shall not exceed 50% of the total development parcel size or ½ acre of irrigated area per acre of development parcel.
3. Temporary irrigation for re-vegetation of areas that were disturbed during construction and that when included exceed the maximum allowable irrigated area set forth herein, may be allowed up to two (2) growing seasons after landscape completion to irrigate and revegetate the disturbed areas.
4. When trees are approved in "natural grass areas" where there is little or no irrigation planned or installed, a sub-surface drip system that does not irrigate beyond the "drip line" of the tree or trees may be installed to water just the trees and as such, will not count as part of the irrigation limits set forth above.

SECTION 3. SAVINGS AND SEVERABILITY- If any section, subsection, paragraph, subparagraph, item, provision, regulation, sentence, clause, or phrase is declared by a Court of competent jurisdiction to be invalid, such actions shall not affect the validity of this ordinance as a whole or any part thereof other than the part declared invalid.

SECTION 4. REPEALER CLAUSE- All City of Sun Valley Ordinances or parts thereof which are in conflict herewith are hereby repealed.

SECTION 5. EFFECTIVE DATE- This Ordinance shall be in full force and effect from and after its approval, passage, and publication as provided by law.

PASSED BY THE CITY COUNCIL OF THE CITY OF SUN VALLEY, IDAHO, AND APPROVED BY THE MAYOR OF THE CITY OF SUN VALLEY on this 21st day of January, 2010.

EFFECTIVE DATE OF PUBLICATION: February 3, 2010.

APPROVED:

Wayne Willich, Mayor
City of Sun Valley

ATTEST:

Kelly Ek, City Clerk
City of Sun Valley



**BLAINE COUNTY BOARD OF COMMISSIONERS
SPECIAL MEETING NOTICE and AGENDA
THURSDAY, MAY 2, 2019**

63-602NN PROPERTY TAX EXEMPTIONS, ACTION ITEMS

- 9:30 SNOW MOUNTAIN APARTMENTS, 2011 Woodside Blvd Hailey**
- 10:00 KETCH, 560 N 1st Ave Ketchum
KETCH 2, 100 E 6th St Ketchum**
- 10:30 JACK BARITEAU, 391 N 1st Ave Ketchum**
- 11:00 DIAMOND SUN APARTMENTS, 231 W 1st St Ketchum**
- 11:30 ALPINE & ASPEN BUILDINGS, 6 & 8 Horseman's Center Rd Sun Valley**
- 12:00 COLD SPRINGS CROSSINGS, 127 Hospital Dr Blaine County**
- 12:30 ADJOURN**

Meeting location: Old Blaine County Courthouse, 206 First Avenue S., Hailey, Idaho 83333

FOR SCHEDULES OF INDIVIDUAL COMMISSIONERS, PLEASE VISIT THE COUNTY WEBSITE WWW.BLAINECOUNTY.ORG

All times are approximate, with the exception of Public Hearings, and are subject to change.

Latest revised agenda printed April 25, 2019 11:51:43 AM

Any person needing special accommodations to participate in the above-noticed meeting should contact the Blaine County recorder at secretary@co.blaine.id.us or telephone 208-788-5505 at least 24 hours prior to the meeting.

1 Parcel Number **Address**
 RPH0475013001B 2011 Woodside Blvd Hailey
District Number **Description**
 20 COUNTY
 21 PSF JAIL BOND
 40 AMBULANCE
 50 RECREATION
 100 HAILEY CITY
 101 HAILEY BOND
 105 TWO YEAR OVERRIDE
 200 SCHOOL DIST #61
 201 SCHOOL PLANT FACILITIES
 500 HAILEY CEM
 700 BIG WOOD FLOOD CONTROL #9

Applicant
 N Snow Mountain Inc.
Abstract Type
 County
 County
 Ambulance
 Recreation
 City
 City
 City
 School
 School
 Cemetery
 Flood Control

Representative
 Scott Niblack
Project Name
 Snow Mountain Apartments
Estimated Investment
 \$7,000,000 - \$9,000,000
Status
 Not started
Plan
 Rehabilitation of existing low-income apartment with 40 units

2 Parcel Number **Address**
 RPK00000350050 100 E 6th St Ketchum
District Number **Description**
 20 COUNTY
 21 PSF JAIL BOND
 40 AMBULANCE
 50 RECREATION
 130 KETCHUM CITY
 200 SCHOOL DIST #61
 201 SCHOOL PLANT FACILITIES
 520 KETCHUM CEM
 132 KETCHUM 003-001
 201 SCHOOL PLANT FACILITIES

Applicant
 Ketchum 2 PDX LLC- Mark Madden
Abstract Type
 County
 County
 Ambulance
 Recreation
 City
 School
 School
 Cemetery
 Urban Renewal
 School

Representative
 Ross Kelley
Project Name
 Ketch 2
Estimated Investment
 \$3,200,000
Status
 Building permit approved
Plan
 New apartment complex with 1 commercial space, 15 market units, and 2 deed restricted units

3 Parcel Number **Address**
 RPK00000350060 560 N 1st Ave Ketchum
District Number **Description**
 20 COUNTY
 21 PSF JAIL BOND
 40 AMBULANCE
 50 RECREATION
 130 KETCHUM CITY
 200 SCHOOL DIST #61
 201 SCHOOL PLANT FACILITIES

Applicant
 Ketchum PDX LLC- Mark Madden
Abstract Type
 County
 County
 Ambulance
 Recreation
 City
 School
 School

Representative
 Ross Kelley
Project Name
 Ketch
Estimated Investment
 \$2,655,000
Status
 Construction to begin in late April
Plan
 New apartment complex with 15 market units and 3 deed restricted units

520 KETCHUM CEM
 132 KETCHUM 003-001
 201 SCHOOL PLANT FACILITIES

4 Parcel Number Address
 RPK00000350060 391 N 1st Ave Ketchum
District Number Description
 20 COUNTY
 21 PSF JAIL BOND
 40 AMBULANCE
 50 RECREATION
 130 KETCHUM CITY
 200 SCHOOL DIST #61

201 SCHOOL PLANT FACILITIES
 520 KETCHUM CEM
 132 KETCHUM 003-001
 201 SCHOOL PLANT FACILITIES

5 Parcel Number Address
 RPK00000620040 231 W 1st St Ketchum
District Number Description
 20 COUNTY
 21 PSF JAIL BOND
 40 AMBULANCE
 50 RECREATION
 130 KETCHUM CITY
 200 SCHOOL DIST #61
 201 SCHOOL PLANT FACILITIES
 520 KETCHUM CEM

6 Parcel Number Address
 RPS0000000001F 6 & 8 Horseman's Center Rd Sun Valley
District Number Description
 20 COUNTY
 21 PSF JAIL BOND
 40 AMBULANCE
 50 RECREATION
 140 SUN VALLEY CITY
 150 SUN VALLEY STREET FUND

Cemetery
 Urban Renewal
 School

Applicant
 Jack Bariteau
Abstract Type
 County
 County
 Ambulance
 Recreation
 City
 School

School
 Cemetery
 Urban Renewal
 School

Applicant
 D & D Diamond Sun LLC
Abstract Type
 County
 County
 Ambulance
 Recreation
 City
 School
 School
 Cemetery

Applicant
 Sun Valley Company
Abstract Type
 County
 County
 Ambulance
 Recreation
 City
 City

Representative
 Jack Bariteau
Project Name
 Estimated Investment
 Status
 Under review- City of Ketchum
 Plan
 Hotel/office space with 15 employee designated apartments, 4 market rate
 apartments, and penthouse residences

Representative
 Jan-Erik Palm
Project Name
 Diamond Sun Apartments
Estimated Investment
 \$500,000
Status
 Under construction
Plan
 Repairs on existing 12 unit apartment complex

Representative
 Tim Silva
Project Name
 Alpine & Aspen Buildings
Estimated Investment
 \$26,500,000
Status
 Under construction
 Plan

Two new apartment buildings with 170 total units

200 SCHOOL DIST #61
 201 SCHOOL PLANT FACILITIES
 400 SUN VALLEY W&S
 410 SV WATER & SEWER BOND 2004
 411 SV WATER & SEWER BOND 2007

School
 School
 Sewer and Water
 Sewer and Water
 Sewer and Water

7 Parcel Number	Address	Applicant	Representative
RP04N18030737D	127 Hospital Dr Blaine County	Cold Springs Crossing LLC	Marc Reinemann
Ditric Number	Description	Abstract Type	Project Name
20	COUNTY	County	Cold Springs Crossings
21	PSF JAIL BOND	County	Estimated Investment
40	AMBULANCE	Ambulance	\$4,500,000
50	RECREATION	Recreation	Status
200	SCHOOL DIST #61	School	Completed 2014
201	SCHOOL PLANT FACILITIES	School	Plan
400	SUN VALLEY W&S	Sewer and Water	New 15-unit apartment complex
410	SV WATER & SEWER BOND 2004	Sewer and Water	
411	SV WATER & SEWER BOND 2007	Sewer and Water	
520	KETCHUM CEM	Cemetery	
600	KETCHUM FIRE	Fire	
610	KET. FIRE BOND	Fire	
700	BIG WOOD FLOOD CONTROL #9	Flood Control	

May 10, 2019

Cust Name

Address 1

Address 2

Dear Cust Name,

Every spring, when water emerges in crawlspaces, sewer flows increase dramatically, due to customers pumping their crawlspaces into the sewer system. District staff monitors the source of this inflow through manual and remote camera observation.

Your home has been identified as a potential contributor to these excess flows, which overload the wastewater treatment plant with water that does not need to be treated.

Please check your crawlspace to determine if your sump pump is connected to the sanitary sewer. If you are connected, the District requests that you replumb your sump to discharge outside rather than into the sewer system.

Delivering sub water to the sanitary sewer is not allowed by District policy and Idaho State Plumbing Code. Issues with crawl space water should be dealt with on site, discharging to the exterior of the home into existing drain channels.

Continued or repeated discharge from a customer's sump pump into the District's sewer system may result in the cancellation of all sewer service to the property until the sump system has been properly and permanently disconnected from the sewer.

Thank you for your cooperation,

Pat McMahon
General Manager